GARDNER DENVER®

301WPD997 Rev A
August, 2005

WELL SERVICING PUMP

MODEL

OPI-600

TRIPLEX PUMP

**FLUID END
PARTS LIST**

Gardner

Denver

**FLUID END PARTS LIST
FOR
OPI-600
WELL SERVICING PUMP**

**MAINTAIN PUMP RELIABILITY AND PERFORMANCE WITH
GENUINE GARDNER DENVER
PARTS AND SUPPORT SERVICES**

Gardner Denver® genuine pump parts are manufactured to design tolerances and are developed for optimum dependability. Design and material innovations are the result of years of experience with hundreds of different pump applications. Reliability in materials and quality assurance is incorporated in our genuine replacement parts.

Your authorized Gardner Denver Sales Office offers all the backup you'll need. The Fort Worth Manufacturing Facility maintains a large inventory of genuine parts.

Gardner Denver supports your needs with these services:

1. Trained parts specialists to assist you in selecting the correct replacement parts.
2. Repair and maintenance kits designed with the necessary parts to simplify servicing your pump.

Authorized service technicians are factory trained and skilled in pump maintenance and repair. They are ready to respond and assist you by providing fast, expert maintenance and repair services.

For the location of your local authorized Gardner Denver distributor, refer to the yellow pages of your phone directory or contact:

Factory (Tulsa): Gardner Denver Well Servicing Pumps 4747 South 83 rd East Avenue Tulsa, Oklahoma 74145	Service Center (Odessa): Chaparral 2121 West 44 th Street Odessa, Tx 79768	Service Center (Ft. Worth): Geoquip 7533 Kathy Lane Ft. Worth, Texas 76126
Phone: (918) 664-1151 (800) 738-8099	Phone: (432) 366-5433 (800) 368-1134	Phone: (817) 249-6400 (800) 824-0271
Fax: (918) 664-6225	Fax: (432) 363-9940	Fax: (817) 249-6401

INSTRUCTIONS FOR ORDERING REPAIR PARTS

When ordering parts, specify Pump MODEL and SERIAL NUMBER (see nameplate on unit). The Serial Number is also stamped on top of the cylinder end of the frame (cradle area).

All orders for Parts should be placed with the Tulsa or Ft. Worth facility.

Where NOT specified, quantity of parts required per pump or unit is one (1); where more than one is required per unit, quantity is indicated in parenthesis. **SPECIFY EXACTLY THE NUMBER OF PARTS REQUIRED.**

GARDNER DENVER PRODUCT WARRANTY

GENERAL PROVISIONS AND LIMITATIONS

Gardner Denver (the "Company") warrants to each original retail purchaser ("Purchaser") of its new products, assemblies or parts from the Company or its authorized distributors that such products are, at the time of delivery to the Purchaser, made with good material and workmanship. No warranty is made with respect to:

1. Any product which has been repaired or altered in such a way, in the Company's judgment, as to affect the product adversely.
2. Any product which has, in the Company's judgment, been subject to negligence, accident, or improper storage, improper installation, operation or application. (Examples: over-pressure, sand-outs, cavitation, corrosion, erosion or degradation).
3. Any product which has not been operated or maintained in accordance with the recommendations of the Company.
4. Components or accessories manufactured, warranted and serviced by others.
Any reconditioned or prior owned product.

Claims for items described in (4) above should be submitted directly to the manufacturer.

WARRANTY PERIOD

The Company's obligation under this warranty is limited to repairing or, at its option, replacing, during normal business hours at an authorized service facility of the Company, any part or assembly which in the Company's judgment proved to have unsatisfactory material or workmanship within the applicable Warranty Period as follows.

Except for the products or components listed below, and subject to the limitations and restrictions set forth in the "Disclaimer" section set forth below, the Warranty Period for all products is 1,250 hours of operation or three (3) months after start-up, not to exceed 120 days after delivery to Purchaser, whichever occurs first. The exceptions are as follows:

1. Power end is warranted for twelve (12) months from date of start-up or eighteen (18) months from date of delivery to the Purchaser, whichever occurs first.
2. Forged steel fluid cylinders are warranted for materials and workmanship for 6 months from the date of installation or 18 months from the

date of delivery to the purchaser, which ever occurs first.

3. Repairs are warranted for 90 days from the date of delivery, for the workmanship and materials of the new parts installed.
4. Weld repaired fluid ends and weld repaired components are not warranted.
5. Expendable fluid end parts, including, but not limited to, valves, valve parts, packing, liners and pistons, are not covered by this warranty due to variable abrasive nature of material pumped.

PRESERVATION ASSEMBLIES DESTINED FOR STORAGE

In order for warranty acceptance any pump assembly not immediately installed or destined to be in storage or in transit for extended periods of time must be prepared for storage as defined in the Company's Long Term Storage Procedure. This includes but is not limited to:

- Drain and thoroughly clean inside power end crankcase.
- Spray rust inhibiting oil on all bearing, machined and inside surfaces of the power end.
- Induce clean gear oil into any circulating pump, filter, heat exchanger and piping.
- Remove valves, seats and plungers from the fluid end. Thoroughly clean and dry these parts and all internal surfaces. Coat all cylinder bores, valve covers and reusable expendable parts with rust preventative.
- Flush all water, and contaminants from pump, tanks, hoses and spray nozzles. Spray all components with a rust inhibiting oil.
- Rotate pump every 30 days to insure bearings are oiled.
- At the expense of the Purchaser, any product properly preserved must be inspected by an authorized agent of the Company, prior to the Company, granting any extended warranty beyond that stated in this warranty.

LABOR TRANSPORTATION AND INSPECTION

The Company will provide labor, by Company representative or authorized service personnel, for repair or replacement of any product or part thereof which in the Company's judgment is proved not to be

as warranted. Labor shall be limited to the amount specified in the Company's labor rate schedule. Labor costs in excess of the Company rate schedules caused by, but not limited to, location or inaccessibility of the equipment, or labor provided by unauthorized service personnel is not provided for by this warranty.

All costs of transportation of product or parts claimed not to be as warranted and, of repaired or replacement parts to or from such service facility shall be borne by the Purchaser. The Company may require the return of any part claimed not to be as warranted to one of its facilities as designated by the Company, transportation prepaid by the Purchaser, to establish a claim under this warranty.

Replacement parts provided under the terms of this warranty are warranted for the remainder of the Warranty Period of the product upon which installed to the same extent as if such parts were original components.

The Company may request a root cause analysis be performed in-order to identify if a request for warranty claim meets the requirements of this warranty.

DISCLAIMER

Except as to title, the foregoing warranty is the sole and exclusive warranty of the Company. The Company hereby extends other manufactures' warranty or guaranties, if any given to Company by such manufacturer, but only to the extent the Company is able to enforce such warranty or guaranties. The Company has not authorized any party to make any representation or warranty other than as expressly set forth herein. SELLER HEREBY DISCLAIMS AND EXCLUDES ANY OTHER EXPRESS, IMPLIED OR STATUTORY WARRANTIES, ARISING BY OPERATION OF LAW OR OTHERWISE, INCLUDING, WITHOUT LIMITATION, ANY WARRANTIES OF MERCHANTABILITY OR FITNESS FOR A PARTICULAR PURPOSE. COMPANY MAKES NO WARRANTIES OR REPRESENTATIONS OF ANY KIND WHATSOEVER (EXPRESS, IMPLIED OR STATUTORY), OF LAW OR OTHERWISE, ON ANY EQUIPMENT, COMPONENT PARTS OR ACCESSORIES SOLD HEREUNDER WHICH, ARE NOT MANUFACTURED BY COMPANY.

NOTWITHSTANDING ANYTHING HEREIN TO THE CONTRARY, THE FOREGOING WARRANTY SHALL BE THE SOLE AND EXCLUSIVE REMEDY

AVAILABLE TO THE PURCHASER. UNDER NO CIRCUMSTANCES, WHETHER IN CONTRACT, TORT OR OTHERWISE, SHALL THE COMPANY'S TOTAL LIABILITY ARISING IN CONNECTION WITH ANY PURCHASE ORDER EXCEED THE AMOUNT OF ANY SALES OR OTHER PROCEEDS RECEIVED PURSUANT THERETO. IN ADDITION, UNDER NO CIRCUMSTANCES, WHETHER IN CONTRACT, TORT OR OTHERWISE, SHALL THE COMPANY BE LIABLE FOR LIQUIDATED, SPECIAL, INDIRECT, INCIDENTAL, EXEMPLARY, OR CONSEQUENTIAL DAMAGES, EXPENSES OR COSTS, INCLUDING, WITHOUT LIMITATION, LOST PROFITS OR FACILITY DOWNTIME, HOWEVER CAUSED AND EVEN IF THE POTENTIAL OF SUCH DAMAGES WAS DISCLOSED AND/OR KNOWN.

No statement, representation, agreement, or understanding, oral or written, made by any agent, distributor, representative, or employee of the Company which is not contained in this Warranty will be binding upon the Company unless made in writing and executed by an officer of the Company.

This warranty shall not be effective as to any claim which is not presented within 30 days after the date upon which the product is claimed not to have been as warranted. Any action for breach of this warranty must be commenced within one year after the date upon which the cause of action occurred.

Any adjustment made pursuant to this warranty shall not be construed as an admission by the Company that any product was not as warranted.

WARRANTY REQUESTS

Products to be returned for warranty analysis shall be approved for return in writing by the Company prior to shipment. All requests for product return shall be submitted by email. Facsimile or letter to:

Warranty Department c/o
Gardner Denver Petroleum Pumps
4747 South 83rd East Avenue
Tulsa, Oklahoma 74145

Email: CCR.QAR@gardnerdenver.com
Facsimile: (918) 664-6225

TABLE OF CONTENTS

2.25" FLUID CYLINDER ASSEMBLY	3
2.75" STANDARD FLUID CYLINDER ASSEMBLY	5
3" STANDARD FLUID CYLINDER ASSEMBLY	7
2.75" AUTOFRETTAGED FLUID CYLINDER ASSEMBLY	9
3" AUTOFRETTAGED FLUID CYLINDER ASSEMBLY	11
3.5" FLUID CYLINDER ASSEMBLY	13
4" FLUID CYLINDER ASSEMBLY	15
4.5" FLUID CYLINDER ASSEMBLY	17
5" FLUID CYLINDER ASSEMBLY	19
RUBBER SPRING LOADED PACKING	20
CDI ADJUSTABLE HNBR PACKING	23
CDI NON-ADJUSTABLE HNBR PACKING	26
DISCHARGE OPTIONS FOR STANDARD FLUID ENDS	29
DISCHARGE OPTIONS FOR AUTOFRETTAGED FLUID ENDS	35
SUCTION MANIFOLD OPTIONS	38
FLUID END SERVICE TOOLS	44
VALVE SEAT PULLER KITS	45

2.25" FLUID CYLINDER ASSEMBLY

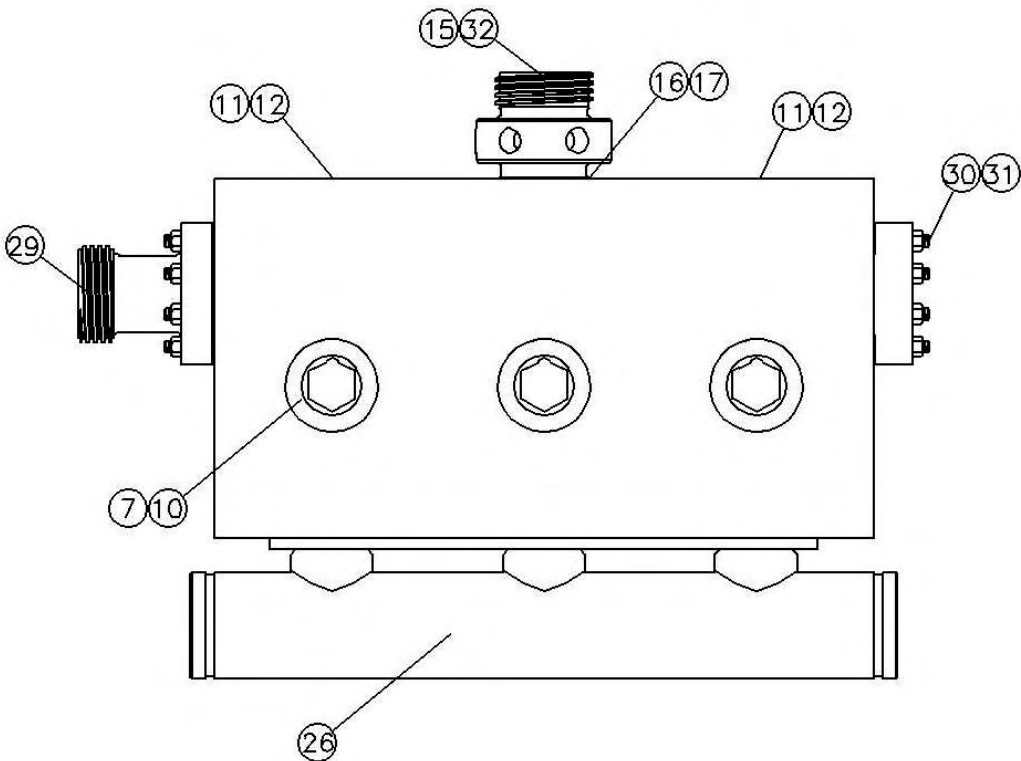
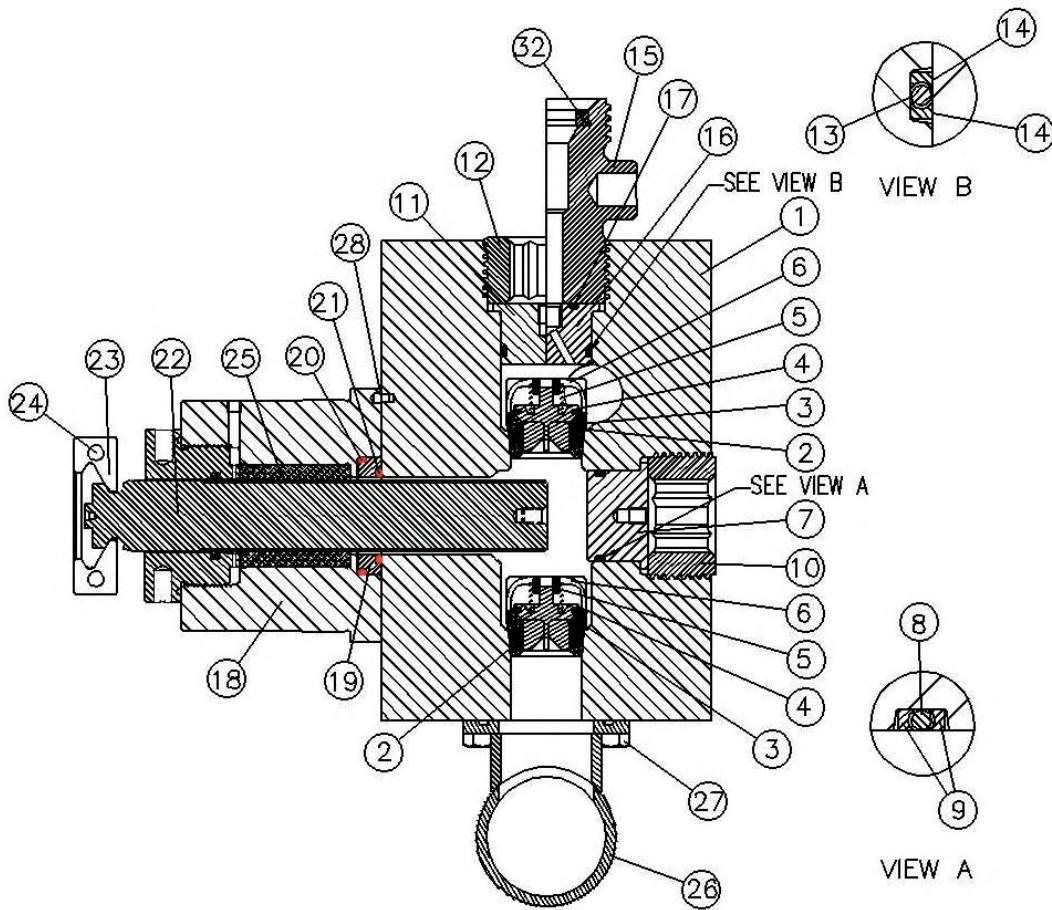

2.25" FLUID CYLINDER ASSEMBLY

Ref No.	Name of Part	Qty.	Part No.
1	Fluid Cylinder, 2.25" CWS	1	013PN002
*	Valve Assembly (Includes Items 2-6)	6	227QBX482
2	Valve Seat (Suction and Discharge)	6	2116460
3	O-ring	6	2116470
4	Valve (Suction and Discharge)	6	2116560
5	Valve Spring (Suction and Discharge)	6	2116473
6	Cage - Valve Spring (Suction and Discharge)	6	2116471
7	Suction Valve Cover	3	086PN010
8	O-ring	3	901SH05-333
9	Back-up Ring (for Item 8)	6	25BC650
10	Retainer Nut – Suction Valve Cover	3	50PN07
11	Discharge Valve Cover – Plain	2	PP1005947
12	Retainer Nut – Discharge Valve Cover – Plain	2	50PN07
13	O-ring	3	901SH05-333
14	Back-up Ring (for Item 13)	6	25BC650
15	Retainer – Discharge Valve Cover – 2" 1502 Gage Connection	1	PP1006009
16	Discharge Valve Cover – Gauge Connection	1	054PN007
17	O-ring	1	107967
18	Stuffing Box – 2.25"	3	200WPD014
19	Seal Carrier – Stuffing Box to Fluid End	3	491PN027
20	O-ring	3	107978
21	O-ring	3	107973
22	Plunger – 2.25"	3	160PN010
23	Plunger Clamp	3	171PN008
24	Screw (Included in Item #23)	6	75P77
25	Packing Group	3	See Pages 20-28
26	Suction Manifold	1	See Pages 38-43
27	Capscrew	12	655EE040
28	Dowel Pin	3	62M20
29	Discharge Flanges		See Pages 29-34
30	Stud	16	450VP003-034
31	Hex Nut	1	50B32
32	Seal – 2" 1502 Weco	1	901SH06-1
***	Fluid End to Frame Bolts (NOT SHOWN)	12	200WPD655

2.75" STANDARD FLUID CYLINDER ASSEMBLY

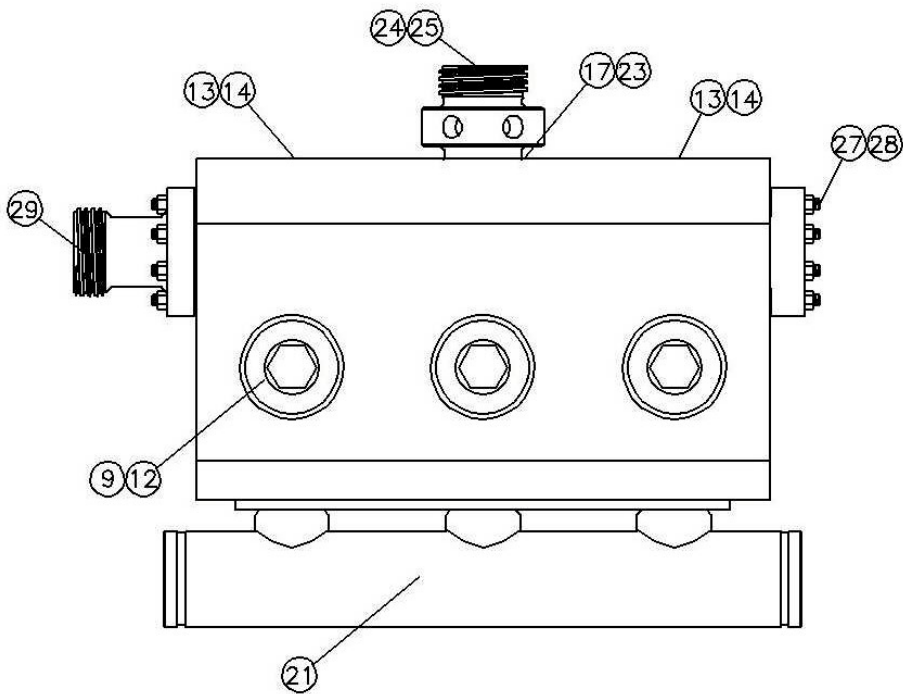
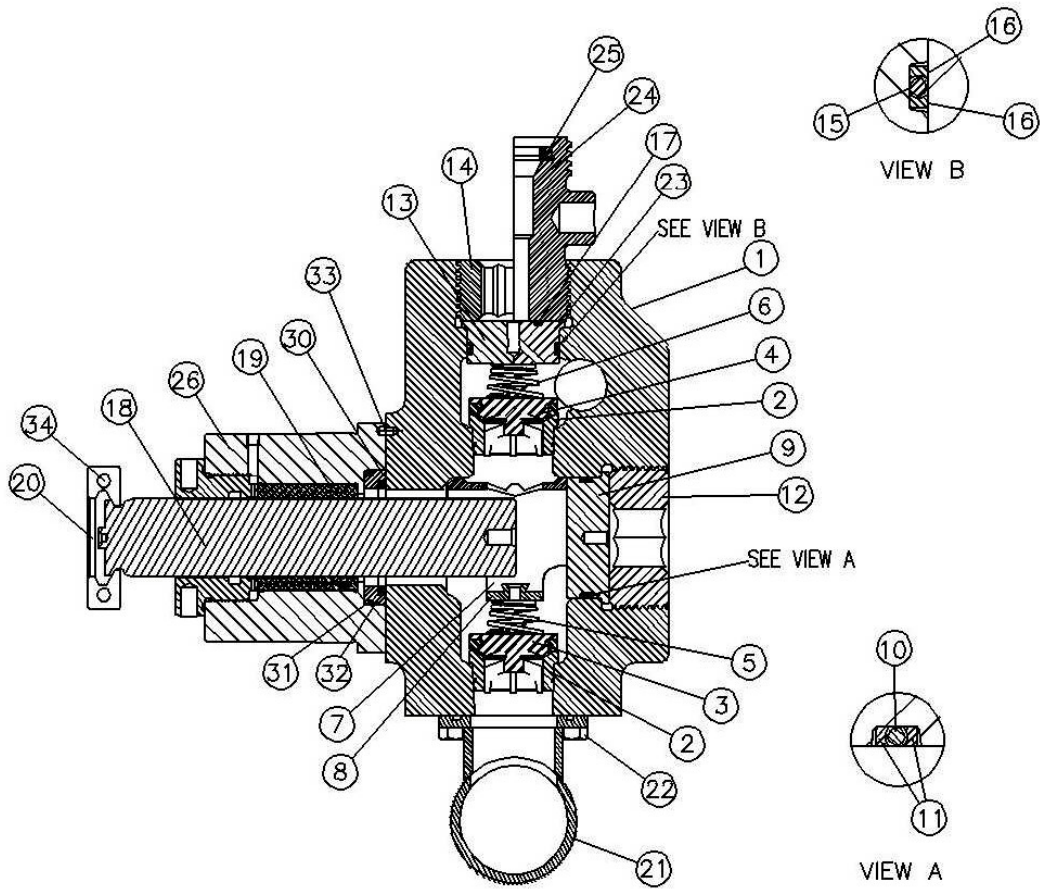

2.75" STANDARD FLUID CYLINDER ASSEMBLY

Ref No.	Name of Part	Qty.	Part No.
1	Fluid Cylinder, 2.75" Standard	1	11PN04
2	Valve Seat (Suction and Discharge) – Mission	6	928SH01-8
	Valve Seat (Suction and Discharge) – Novatech	6	101376
3	Suction Valve – Mission (No Burst Disk)	3	927SH01-7
	Suction Valve – Novatech (No Burst Disk)	3	101914
	Suction Valve – Mission with 22.5k Burst Disk	3	301WPD482
4	Discharge Valve – Mission	3	927SH01-7
	Discharge Valve – Novatech	3	101914
5	Valve Spring – Suction	3	918VP024
6	Valve Spring – Discharge	3	918VP024
7	Suction Spring Retainer – Cage	3	131PN06
8	Suction Valve Stop	3	130PN09
9	Suction Valve Cover	3	302WPD147
10	O-ring	3	107981
11	Back-up Ring (for Item 10)	6	25BC652
12	Retainer Nut – Suction Valve Cover	3	50PN06
13	Discharge Valve Cover – Plain	2	300WPD147
14	Retainer Nut – Discharge Valve Cover – Plain	2	50PN07
15	O-ring	3	107975
16	Back-up Ring (for Item 15)	6	25BC651
17	O-ring	1	107967
18	Plunger – 2.75"	3	202WPD038
19	Packing Group	3	See Pages 20-28
20	Plunger Clamp	3	170PN04
21	Suction Manifold	1	See Pages 38-43
22	Screw	12	655EE040
23	Discharge Valve Cover – Gauge Connection	1	301WPD147
24	Retainer – Discharge Valve Cover – 2" 1502 Gage Connection	1	054PN007
25	Seal – 2" 1502 Weco	1	901SH06-1
26	Stuffing Box – 2.75"	3	202WPD014
27	Stud	16	450VP003-034
28	Hex Nut	16	50B32
29	Discharge Flanges		See Pages 29-34
30	Seal Carrier – Stuffing Box to Fluid End	3	491PN016
31	O-ring	3	185351
32	Seal	3	901SH13-7
33	Dowel Pin	3	62M20
34	Screw (Included in Item #20)	6	75P77
***	Fluid End to Frame Bolts (NOT SHOWN)	12	200WPD655

3" STANDARD FLUID CYLINDER ASSEMBLY

Ref No.	Name of Part	Qty.	Part No.
1	Fluid Cylinder, 3" Standard	1	11PN04
2	Valve Seat (Suction and Discharge) – Mission	6	928SH01-8
	Valve Seat (Suction and Discharge) – Novatech	6	101376
3	Suction Valve – Mission (No Burst Disk)	3	927SH01-7
	Suction Valve – Novatech (No Burst Disk)	3	101914
	Suction Valve – Mission with Burst Disk	3	301WPD482
4	Discharge Valve – Mission	3	927SH01-7
	Discharge Valve – Novatech	3	101914
5	Valve Spring – Suction	3	918VP024
6	Valve Spring – Discharge	3	918VP024
7	Suction Spring Retainer – Cage	3	131PN06
8	Suction Valve Stop	3	130PN09
9	Suction Valve Cover	3	302WPD147
10	O-ring	3	107981
11	Back-up Ring (for Item 10)	6	25BC652
12	Retainer Nut – Suction Valve Cover	3	50PN06
13	Discharge Valve Cover – Plain	2	300WPD147
14	Retainer Nut – Discharge Valve Cover – Plain	2	50PN07
15	O-ring	3	107975
16	Back-up Ring (for Item 15)	6	25BC651
17	O-ring	1	107967
18	Plunger – 3"	3	201WPD038
19	Packing Group	3	See Pages 20-28
20	Plunger Clamp	3	170PN04
21	Suction Manifold	1	See Pages 38-43
22	Screw	12	655EE040
23	Discharge Valve Cover – Gauge Connection	1	301WPD147
24	Retainer – Discharge Valve Cover – 2" 1502 Gage Connection	1	054PN007
25	Seal – 2" 1502 Weco	1	901SH06-1
26	Stuffing Box – 3"	3	204WPD014
27	Stud	16	450VP003-034
28	Hex Nut	16	50B32
29	Discharge Flanges		See Pages 29-34
30	Seal Carrier – Stuffing Box to Fluid End	3	491PN016
31	O-ring	3	185351
32	Seal	3	901SH13-7
33	Dowel Pin	3	62M20
34	Screw	6	75P77
***	Fluid End to Frame Bolts (NOT SHOWN)	12	200WPD655

2.75" AUTOFRETTAGED FLUID CYLINDER ASSEMBLY

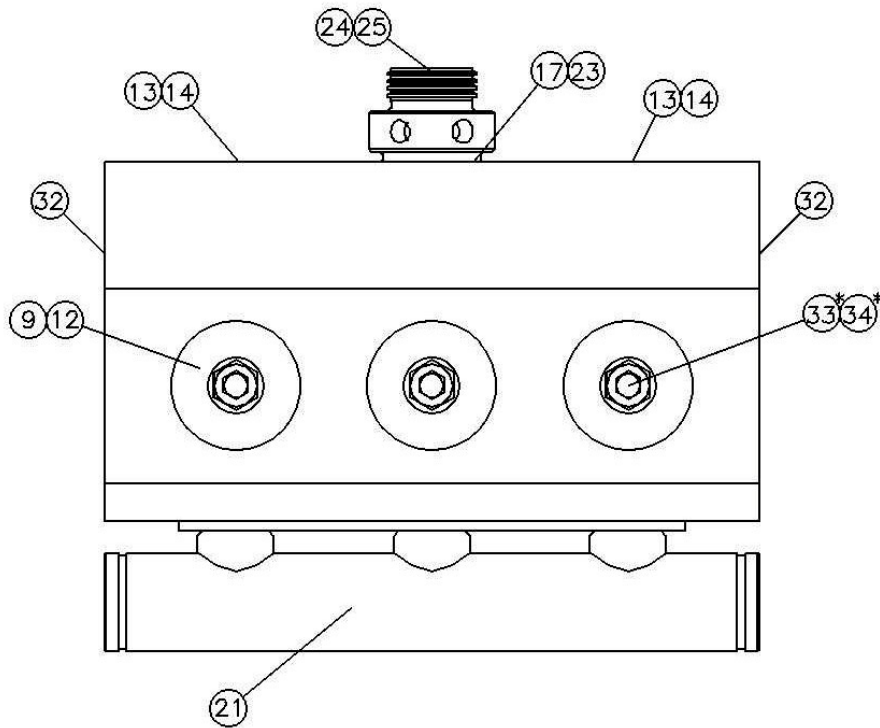
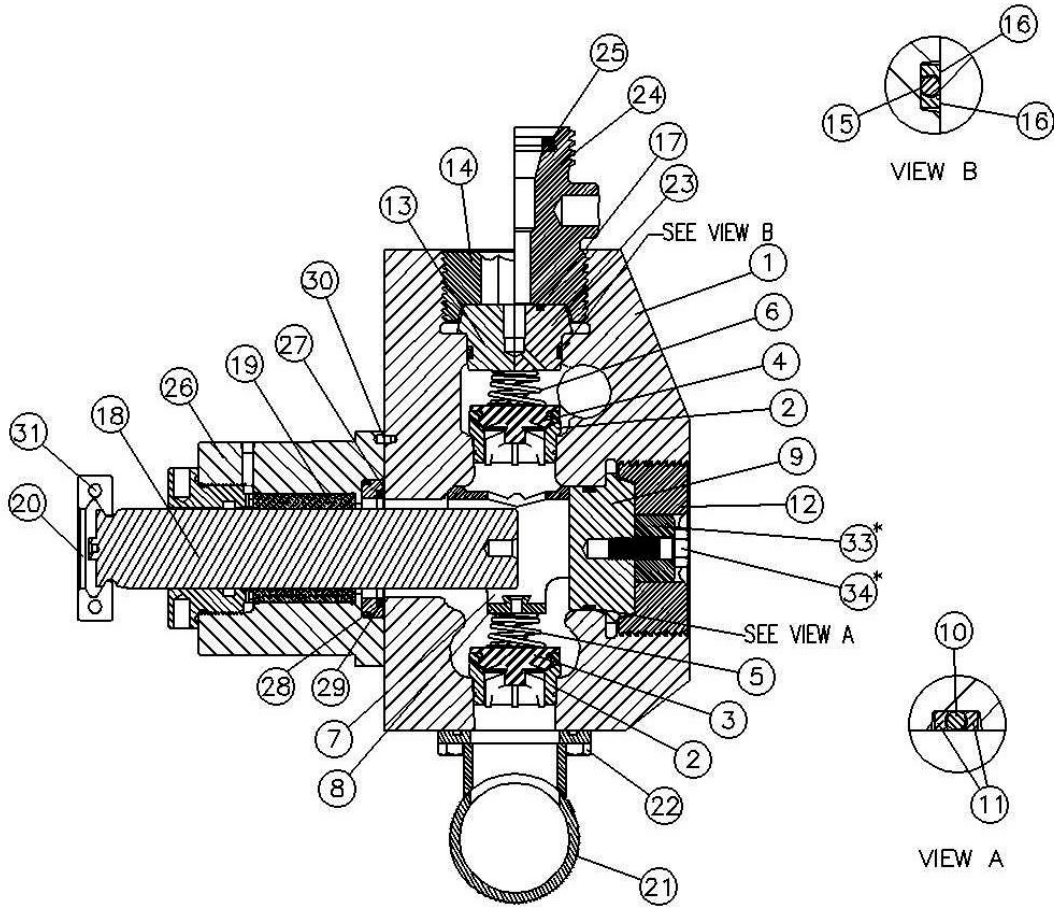

2.75" AUTOFRETTAGED FLUID CYLINDER ASSEMBLY

Ref No.	Name of Part	Qty.	Part No.
1	Fluid Cylinder, 2.75" Autofrettagged	1	303WPD029
2	Valve Seat (Suction and Discharge) – Mission	6	928SH01-8
	Valve Seat (Suction and Discharge) – Novatech	6	101376
3	Suction Valve – Mission (No Burst Disk)	3	927SH01-7
	Suction Valve – Novatech (No Burst Disk)	3	101914
	Suction Valve – Mission with Burst Disk	3	301WPD482
4	Discharge Valve – Mission	3	927SH01-7
	Discharge Valve – Novatech	3	101914
5	Valve Spring – Suction	3	918VP024
6	Valve Spring – Discharge	3	918VP024
7	Suction Spring Retainer – Cage	3	131PN06
8	Suction Valve Stop	3	130PN09
9	Suction Valve Cover	3	313WPD147
10	O-ring	3	107981
11	Back-up Ring (for Item 10)	6	25BC652
12	Retainer Nut – Suction Valve Cover	3	305WPD205
13	Discharge Valve Cover – Plain	2	314WPD147
14	Retainer Nut – Discharge Valve Cover – Plain	2	303WPD205
15	O-ring	3	107975
16	Back-up Ring (for Item 15)	6	25BC651
17	O-ring	1	107967
18	Plunger – 2.75"	3	202WPD038
19	Packing Group	3	See Pages 20-28
20	Plunger Clamp	3	170PN04
21	Suction Manifold	1	See Pages 38-43
22	Screw	12	655EE040
23	Discharge Valve Cover – Gauge Connection	1	315WPD147
24	Retainer – Discharge Valve Cover – 2" 1502 Gage Connection	1	304WPD205
25	Seal – 2" 1502 Weco	1	901SH06-1
26	Stuffing Box – 2.75"	3	202WPD014
27	Seal Carrier – Stuffing Box to Fluid End	3	491PN016
28	O-ring	3	185351
29	Seal	3	901SH13-7
30	Dowel Pin	3	62M20
31	Screw	6	75P77
32	Discharge Flanges		See Pages 35-37
*	OPTIONAL ITEMS:		
33	Valve Cover Lock	3	PP1001357
34	Lock Bolt – Left-hand Thread	3	PP1001506
***	Fluid End to Frame Bolts (NOT SHOWN)	12	200WPD655

3" AUTOFRETTAGED FLUID CYLINDER ASSEMBLY

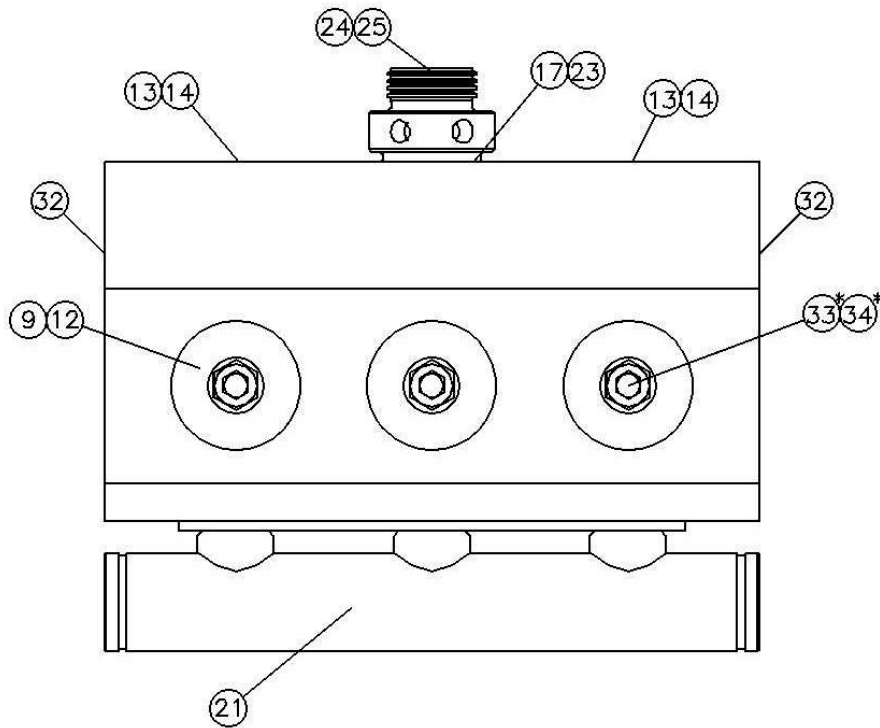
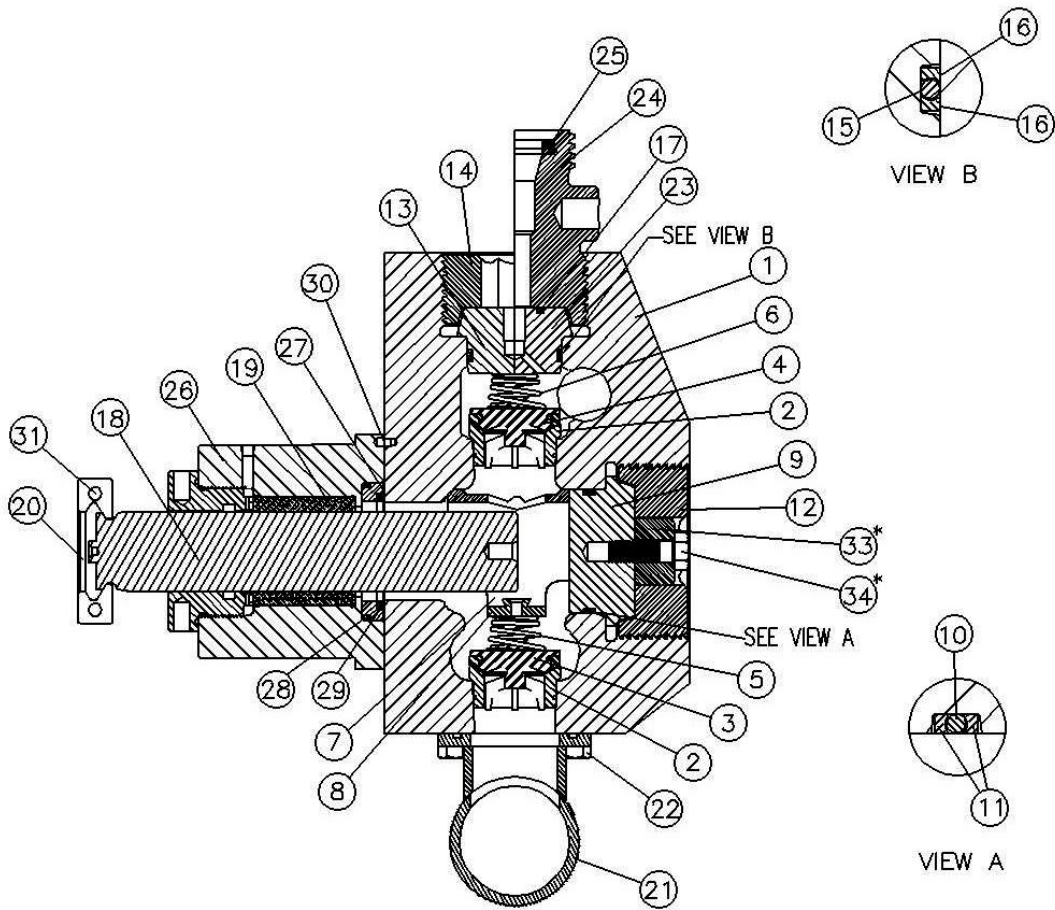

3" AUTOFRETTAGED FLUID CYLINDER ASSEMBLY

Ref No.	Name of Part	Qty.	Part No.
1	Fluid Cylinder, 3" Autofrettagged	1	303WPD029
2	Valve Seat (Suction and Discharge) – Mission	6	928SH01-8
	Valve Seat (Suction and Discharge) – Novatech	6	101376
3	Suction Valve – Mission (No Burst Disk)	3	927SH01-7
	Suction Valve – Novatech (No Burst Disk)	3	101914
	Suction Valve – Mission with Burst Disk	3	301WPD482
4	Discharge Valve – Mission	3	927SH01-7
	Discharge Valve – Novatech	3	101914
5	Valve Spring – Suction	3	918VP024
6	Valve Spring – Discharge	3	918VP024
7	Suction Spring Retainer – Cage	3	131PN06
8	Suction Valve Stop	3	130PN09
9	Suction Valve Cover	3	313WPD147
10	O-ring	3	107981
11	Back-up Ring (for Item 10)	6	25BC652
12	Retainer Nut – Suction Valve Cover	3	305WPD205
13	Discharge Valve Cover – Plain	2	314WPD147
14	Retainer Nut – Discharge Valve Cover – Plain	2	303WPD205
15	O-ring	3	107975
16	Back-up Ring (for Item 15)	6	25BC651
17	O-ring	1	107967
18	Plunger – 3"	3	201WPD038
19	Packing Group	3	See Pages 20-28
20	Plunger Clamp	3	170PN04
21	Suction Manifold	1	See Pages 38-43
22	Screw	12	655EE040
23	Discharge Valve Cover – Gauge Connection	1	315WPD147
24	Retainer – Discharge Valve Cover – 2" 1502 Gage Connection	1	304WPD205
25	Seal – 2" 1502 Weco	1	901SH06-1
26	Stuffing Box – 3"	3	204WPD014
27	Seal Carrier – Stuffing Box to Fluid End	3	491PN016
28	O-ring	3	185351
29	Seal	3	901SH13-7
30	Dowel Pin	3	62M20
31	Screw	6	75P77
32	Discharge Flanges		See Pages 35-37
*	OPTIONAL ITEMS:		
33	Valve Cover Lock	3	PP1001357
34	Lock Bolt – Left-hand Thread	3	PP1001506
***	Fluid End to Frame Bolts (NOT SHOWN)	12	200WPD655

3.5" FLUID CYLINDER ASSEMBLY

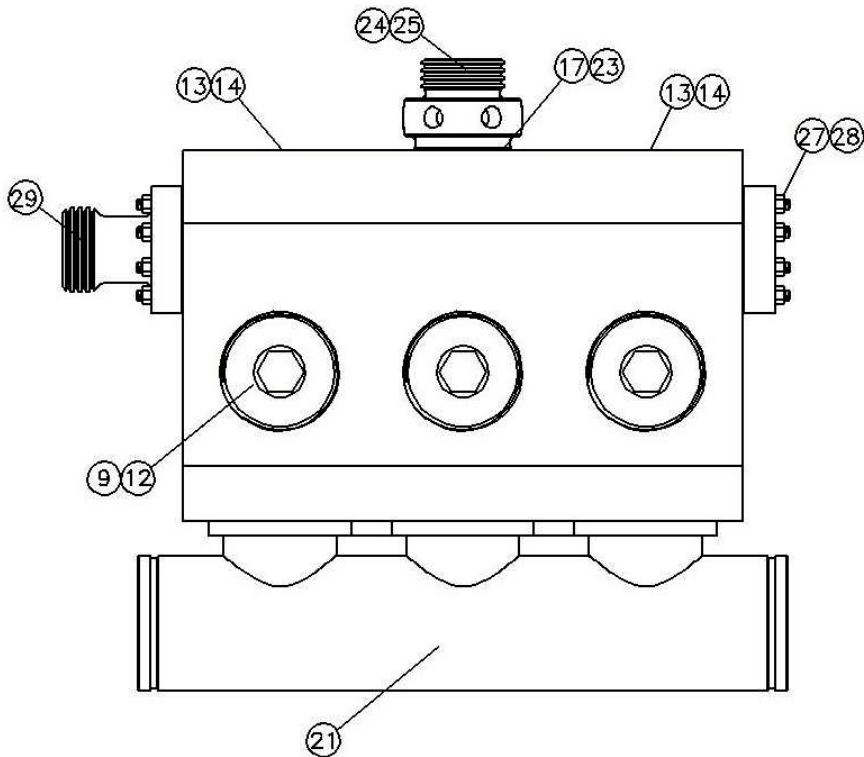
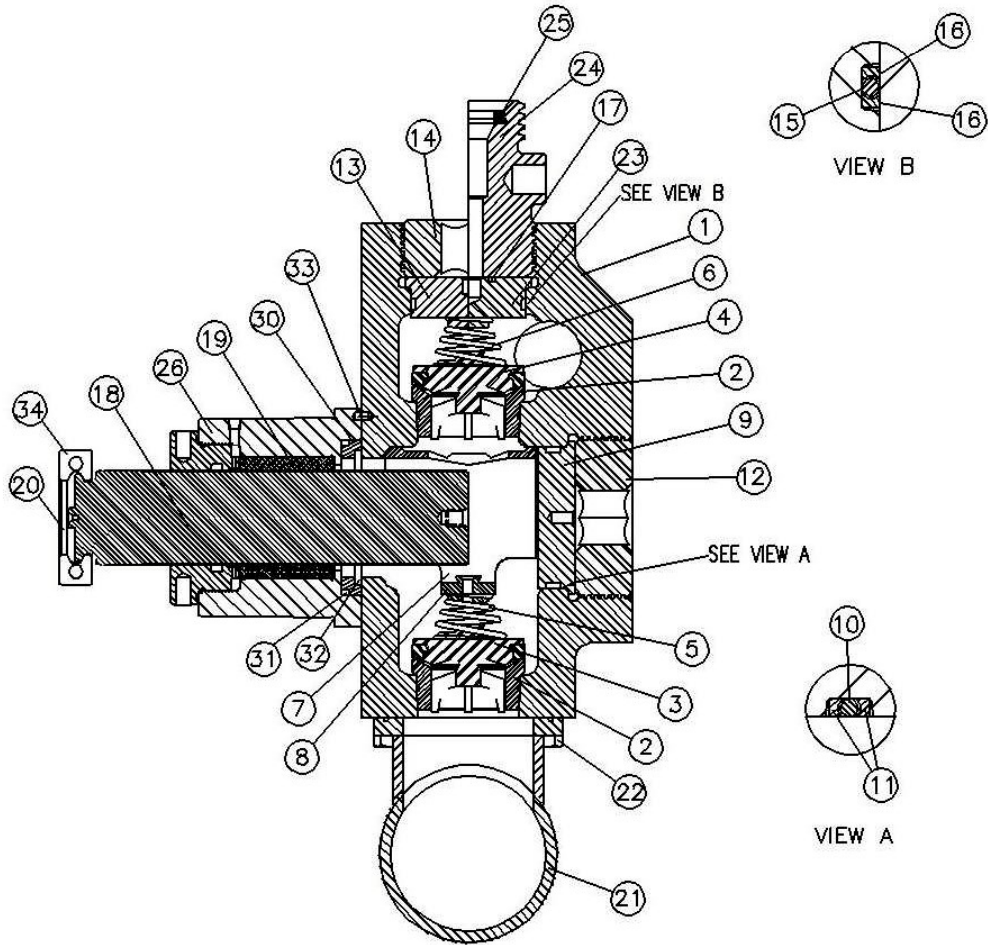

3.5" FLUID CYLINDER ASSEMBLY

Ref No.	Name of Part	Qty.	Part No.
1	Fluid Cylinder, 3.5"	1	11PN03
2	Valve Seat (Suction and Discharge) – Mission	6	928SH01-4
	Valve Seat (Suction and Discharge) – Novatech	6	100199
3	Suction Valve – Mission (No Burst Disk)	3	927VP010-003
	Suction Valve – Novatech (No Burst Disk)	3	TUL101778
	Suction Valve – Mission with 22.5k Burst Disk	3	302WPD482
4	Discharge Valve – Mission	3	927VP010-003
	Discharge Valve – Novatech	3	TUL101778
5	Valve Spring – Suction	3	918VP023
6	Valve Spring – Discharge	3	918VP023
7	Suction Spring Retainer – Cage	3	131PN07
8	Suction Valve Stop	3	130PN08
9	Suction Valve Cover	3	305WPD147
10	O-ring	3	107985
11	Back-up Ring (for Item 10)	6	25BC658
12	Retainer Nut – Suction Valve Cover	3	50PN08
13	Discharge Valve Cover – Plain	2	303WPD147
14	Retainer Nut – Discharge Valve Cover – Plain	2	50PN06
15	O-ring	3	107981
16	Back-up Ring (for Item 15)	6	25BC652
17	O-ring	1	107967
18	Plunger – 3.5"	3	203WPD038
19	Packing Group	3	See Pages 20-28
20	Plunger Clamp	3	170PN03
21	Suction Manifold	1	See Pages 38-43
22	Screw	12	655EF060
23	Discharge Valve Cover – Gauge Connection	1	304WPD147
24	Retainer – Discharge Valve Cover – 2" 1502 Gage Connection	1	054PN009
25	Seal – 2" 1502 Weco	1	901SH06-1
26	Stuffing Box – 3.5"	3	206WPD014
27	Stud	16	450VP003-034
28	Hex Nut	16	50B32
29	Discharge Flanges		See Pages 29-34
30	Seal Carrier – Stuffing Box to Fluid End	3	491PN017
31	O-ring	3	162810
32	Seal	3	901SH13-2
33	Dowel Pin	3	62M20
34	Screw	6	75P77
***	Fluid End to Frame Bolts (NOT SHOWN)	12	200WPD655

4" FLUID CYLINDER ASSEMBLY

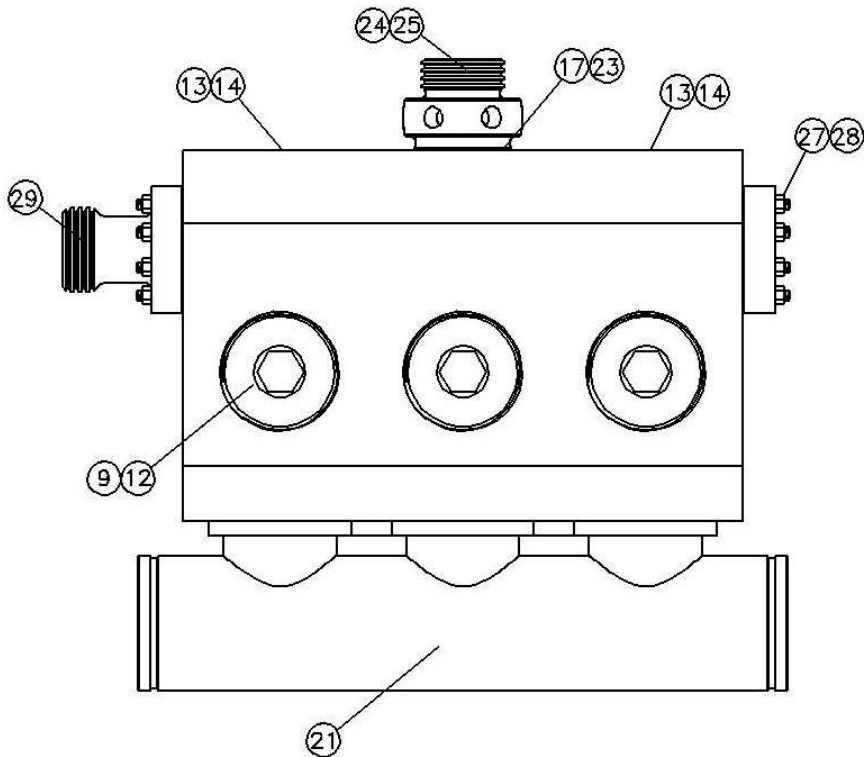
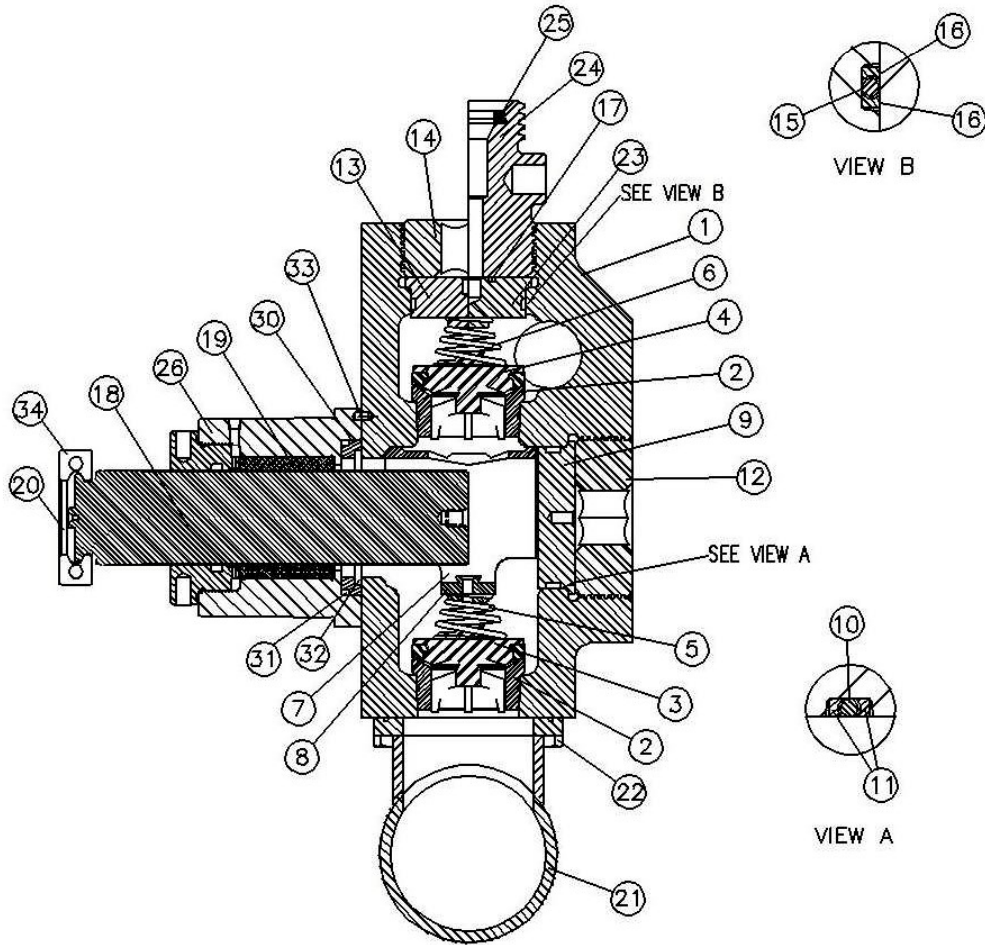

4" FLUID CYLINDER ASSEMBLY

Ref No.	Name of Part	Qty.	Part No.
1	Fluid Cylinder, 4"	1	11PN03
2	Valve Seat (Suction and Discharge) – Mission	6	928SH01-4
	Valve Seat (Suction and Discharge) – Novatech	6	100199
3	Suction Valve – Mission (No Burst Disk)	3	927VP010-003
	Suction Valve – Novatech (No Burst Disk)	3	TUL101778
	Suction Valve – Mission with Burst Disk	3	302WPD482
4	Discharge Valve – Mission	3	927VP010-003
	Discharge Valve – Novatech	3	TUL101778
5	Valve Spring – Suction	3	918VP023
6	Valve Spring – Discharge	3	918VP023
7	Suction Spring Retainer – Cage	3	131PN07
8	Suction Valve Stop	3	130PN08
9	Suction Valve Cover	3	305WPD147
10	O-ring	3	107985
11	Back-up Ring (for Item 10)	6	25BC658
12	Retainer Nut – Suction Valve Cover	3	50PN08
13	Discharge Valve Cover – Plain	2	303WPD147
14	Retainer Nut – Discharge Valve Cover – Plain	2	50PN06
15	O-ring	3	107981
16	Back-up Ring (for Item 15)	6	25BC652
17	O-ring	1	107967
18	Plunger – 4"	3	200WPD038
19	Packing Group	3	See Pages 20-28
20	Plunger Clamp	3	170PN03
21	Suction Manifold	1	See Pages 38-43
22	Screw	12	655EF060
23	Discharge Valve Cover – Gauge Connection	1	304WPD147
24	Retainer – Discharge Valve Cover – 2" 1502 Gage Connection	1	054PN009
25	Seal – 2" 1502 Weco	1	901SH06-1
26	Stuffing Box – 4"	3	209WPD014
27	Stud	16	450VP003-034
28	Hex Nut	16	50B32
29	Discharge Flanges		See Pages 29-34
30	Seal Carrier – Stuffing Box to Fluid End	3	491PN017
31	O-ring	3	162810
32	Seal	3	901SH13-2
33	Dowel Pin	3	62M20
34	Screw	6	75P77
***	Fluid End to Frame Bolts (NOT SHOWN)	12	200WPD655

4.5" FLUID CYLINDER ASSEMBLY

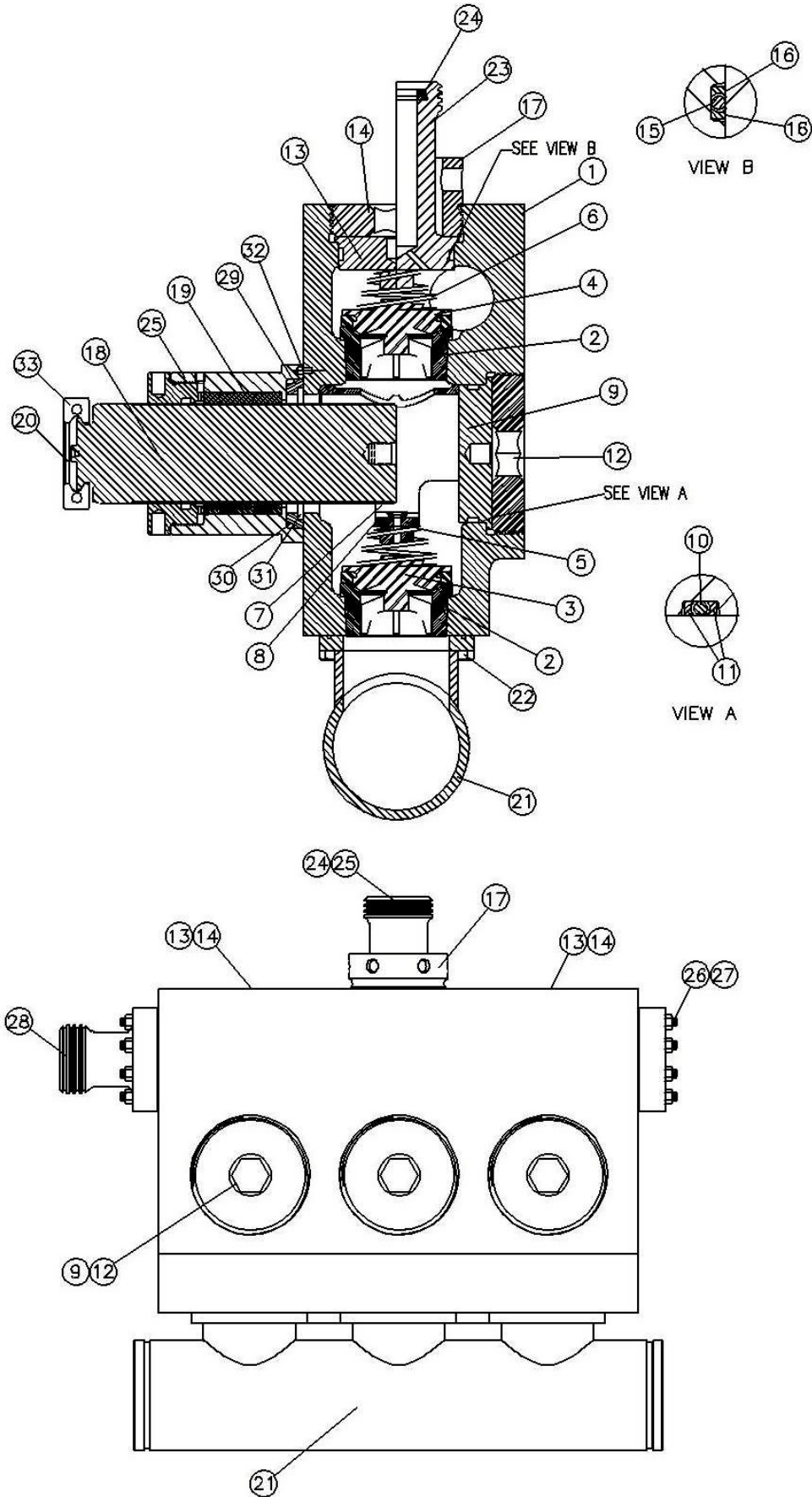

4.5" FLUID CYLINDER ASSEMBLY

Ref No.	Name of Part	Qty.	Part No.
1	Fluid Cylinder, 4.5"	1	11PN02
2	Valve Seat (Suction and Discharge) – Mission	6	928SH01-3
	Valve Seat (Suction and Discharge) – Novatech	6	101489
3	Suction Valve – Mission (No Burst Disk)	3	927VP010-004
	Suction Valve – Novatech (No Burst Disk)	3	101469
	Suction Valve – Mission with 22.5k Burst Disk	3	PP1003832
4	Discharge Valve – Mission	3	927VP010-004
	Discharge Valve – Novatech	3	101469
5	Valve Spring – Suction	3	918PN06
6	Valve Spring – Discharge	3	918PN06
7	Suction Spring Retainer – Cage	3	131PN04
8	Suction Valve Stop	3	130PN06
9	Suction Valve Cover	3	307WPD147
10	O-ring	3	107990
11	Back-up Ring (for Item 10)	6	25BC661
12	Retainer Nut – Suction Valve Cover	3	50PN05
13	Discharge Valve Cover – Plain	2	306WPD147
14	Retainer Nut – Discharge Valve Cover – Plain	2	50PN04
15	O-ring	3	107985
16	Back-up Ring (for Item 15)	6	25BC658
17	Retainer Nut – Discharge Valve Cover Gauge Connection	3	54PN05
18	Plunger –4.5"	3	204WPD038
19	Packing Group	3	See Pages 20-28
20	Plunger Clamp	1	170PN03
21	Suction Manifold	12	See Pages 38-43
22	Screw	1	655EF060
23	Discharge Valve Cover – Gauge Connection	1	72PN10
24	Seal – 2" 1502 Weco	1	901SH06-1
25	Stuffing Box – 4.5"	3	211WPD014
26	Stud	8	79AJ5
27	Hex Nut	16	50B34
28	Discharge Flanges		See Pages 29-34
29	Seal Carrier – Stuffing Box to Fluid End	3	491PN018
30	O-ring	3	107991
31	Seal	3	901SH13-5
32	Dowel Pin	3	62M20
33	Screw	6	75P77
***	Fluid End to Frame Bolts (NOT SHOWN)	12	200WPD655

5" FLUID CYLINDER ASSEMBLY

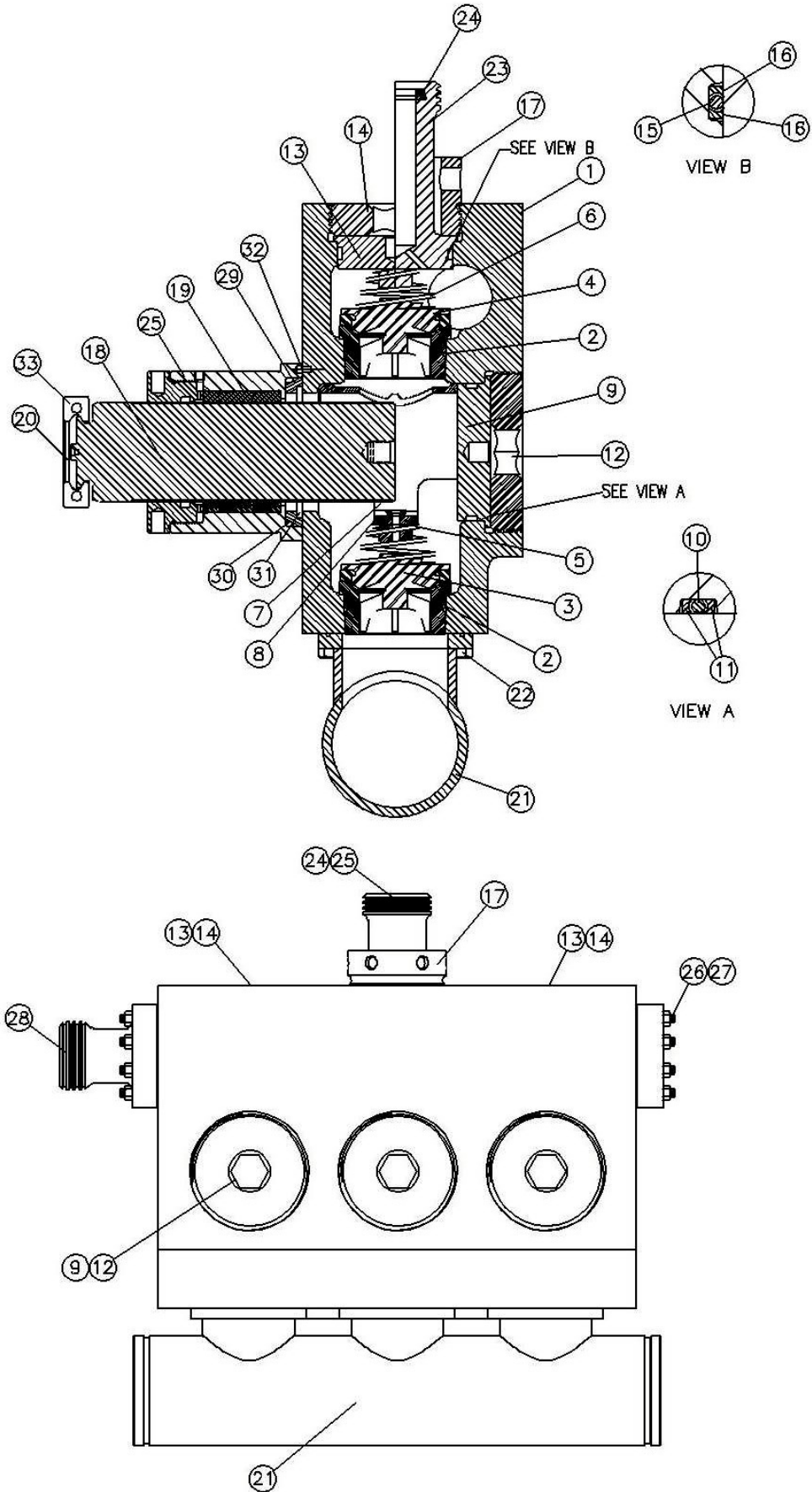

5" FLUID CYLINDER ASSEMBLY

Ref No.	Name of Part	Qty.	Part No.
1	Fluid Cylinder, 5"	1	11PN02
2	Valve Seat (Suction and Discharge) – Mission	6	928SH01-3
	Valve Seat (Suction and Discharge) – Novatech	6	101489
3	Suction Valve – Mission (No Burst Disk)	3	927VP010-004
	Suction Valve – Novatech (No Burst Disk)	3	101469
	Suction Valve – Mission with Burst Disk	3	PP1003832
4	Discharge Valve – Mission	3	927VP010-004
	Discharge Valve – Novatech	3	101469
5	Valve Spring – Suction	3	918PN06
6	Valve Spring – Discharge	3	918PN06
7	Suction Spring Retainer – Cage	3	131PN04
8	Suction Valve Stop	3	130PN06
9	Suction Valve Cover	3	307WPD147
10	O-ring	3	107990
11	Back-up Ring (for Item 10)	6	25BC661
12	Retainer Nut – Suction Valve Cover	3	50PN05
13	Discharge Valve Cover – Plain	2	306WPD147
14	Retainer Nut – Discharge Valve Cover – Plain	2	50PN04
15	O-ring	3	107985
16	Back-up Ring (for Item 15)	6	25BC658
17	Retainer Nut – Discharge Valve Cover Gauge Connection	3	54PN05
18	Plunger – 5"	3	205WPD038
19	Packing Group	3	See Pages 20-28
20	Plunger Clamp	3	170PN03
21	Suction Manifold	1	See Pages 38-43
22	Screw	12	655EF060
23	Discharge Valve Cover – Gauge Connection	1	72PN10
24	Seal – 2" 1502 Weco	1	901SH06-1
25	Stuffing Box – 5"	3	213WPD014
26	Stud	8	79AJ5
27	Hex Nut	8	50B34
28	Discharge Flanges		See Pages 29-34
29	Seal Carrier – Stuffing Box to Fluid End	3	491PN018
30	O-ring	3	107991
31	Seal	3	901SH13-5
32	Dowel Pin	3	62M20
33	Screw	6	75P77
***	Fluid End to Frame Bolts (NOT SHOWN)	12	200WPD655

RUBBER SPRING LOADED PACKING

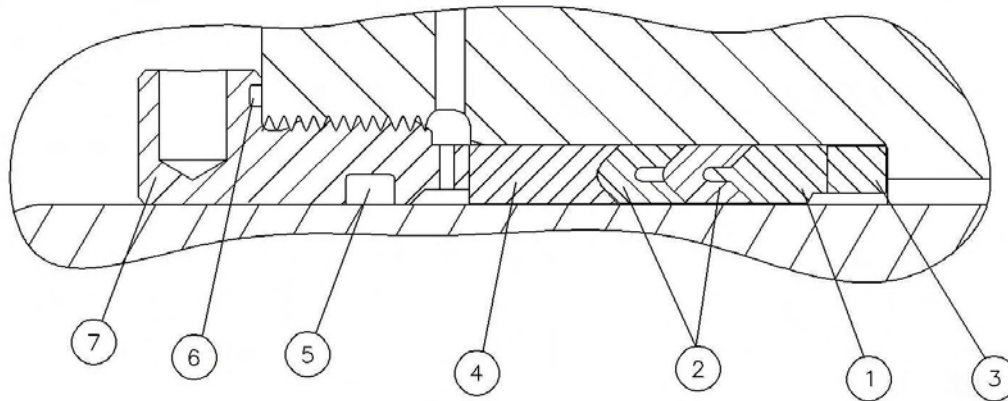

2.25" RSL PACKING ASSEMBLY

Ref No.	Name of Part	Qty.	Part No.
1	HEADER RING, 2.25"	1	901VP014-019
2	PRESSURE RING	2	901VP002-019
3	SPACER	1	206WPD144
4	FEMALE ADAPTER	1	203PN001-015
5	WIPER SEAL	1	60AM50
6	O-RING	1	137866
7	PACKING NUT	1	182PN025

2.75" RSL PACKING ASSEMBLY

Ref No.	Name of Part	Qty.	Part No.
1	HEADER RING, 2.75"	1	901VP014-013
2	PRESSURE RING	2	901VP002-013
3	SPACER	1	200WPD144
4	FEMALE ADAPTER	1	203PN001-009
5	WIPER SEAL	1	60AM82
6	O-RING	1	137866
7	PACKING NUT	1	308WPD008

3" RSL PACKING ASSEMBLY

Ref No.	Name of Part	Qty.	Part No.
1	HEADER RING, 3"	1	901VP014-002
2	PRESSURE RING	2	901VP002-002
3	SPACER	1	201WPD144
4	FEMALE ADAPTER	1	203PN001-001
5	WIPER SEAL	1	595710000
6	O-RING	1	137866
7	PACKING NUT	1	309WPD008

RUBBER SPRING LOADED PACKING

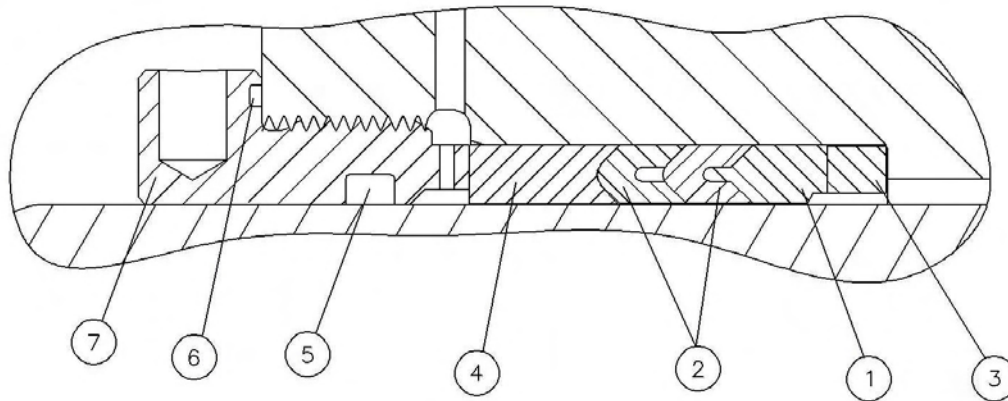

3.5" RSL PACKING ASSEMBLY

Ref No.	Name of Part	Qty.	Part No.
1	HEADER RING, 3.5"	1	901VP014-012
2	PRESSURE RING	2	901VP002-012
3	SPACER	1	202WPD144
4	FEMALE ADAPTER	1	203PN001-007
5	WIPER SEAL	1	60AM83
6	O-RING	1	901SH05-256
7	PACKING NUT	1	310WPD008

4" RSL PACKING ASSEMBLY

Ref No.	Name of Part	Qty.	Part No.
1	HEADER RING, 4"	1	901VP014-005
2	PRESSURE RING	2	901VP002-005
3	SPACER	1	203WPD144
4	FEMALE ADAPTER	1	203PN001-003
5	WIPER SEAL	1	60AM84
6	O-RING	1	901SH05-256
7	PACKING NUT	1	311WPD008

4.5" RSL PACKING ASSEMBLY

Ref No.	Name of Part	Qty.	Part No.
1	HEADER RING, 4.5"	1	901VP014-014
2	PRESSURE RING	2	901VP002-014
3	SPACER	1	204WPD144
4	FEMALE ADAPTER	1	203PN001-005
5	WIPER SEAL	1	60AM73
6	O-RING	1	108515
7	PACKING NUT	1	312WPD008

RUBBER SPRING LOADED PACKING

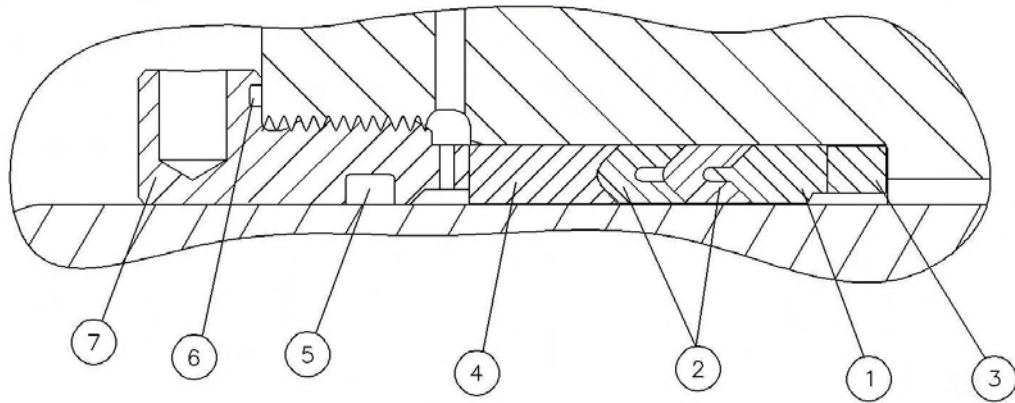

5.0" RSL PACKING ASSEMBLY

Ref No.	Name of Part	Qty.	Part No.
1	HEADER RING, 5"	1	901VP014-009
2	PRESSURE RING	2	901VP002-009
3	SPACER	1	205WPD144
4	FEMALE ADAPTER	1	203PN001-006
5	WIPER SEAL	1	60AM74
6	O-RING	1	167661
7	PACKING NUT	1	313WPD008

CDI ADJUSTABLE HNBR PACKING

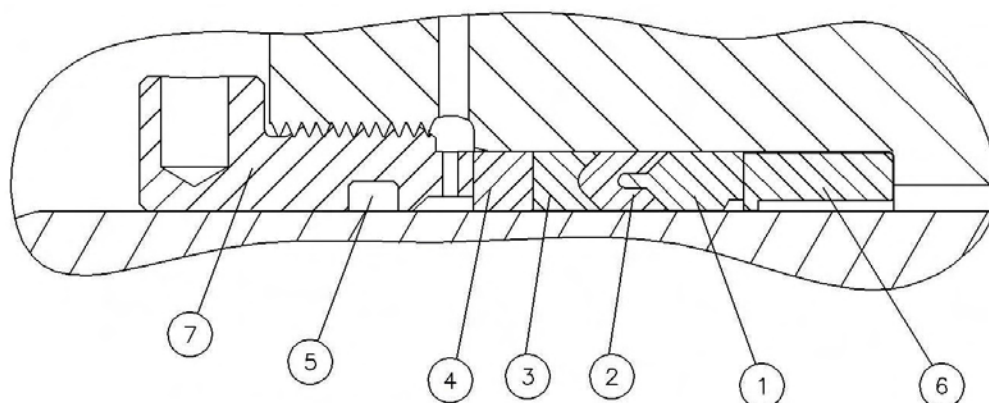

2.25" CDI ADJUSTABLE HNBR PACKING ASSEMBLY

Ref No.	Name of Part	Qty.	Part No.
1	HEADER RING, 2.25"	1	300OPE222
2	PRESSURE RING	1	307OPE222
3	FEMALE ADAPTER	1	306OPE170
4	SPACER	1	300OPE144
5	WIPER SEAL	1	60AM81
6	JUNK RING	1	300OPE317
7	PACKING NUT	1	300WPD008

2.75" CDI ADJUSTABLE HNBR PACKING ASSEMBLY

Ref No.	Name of Part	Qty.	Part No.
1	HEADER RING, 2.75"	1	301OPE222
2	PRESSURE RING	1	308OPE222
3	FEMALE ADAPTER	1	307OPE170
4	SPACER	1	301OPE144
5	WIPER SEAL	1	60AM82
6	JUNK RING	1	301OPE317
7	PACKING NUT	1	301WPD008

3" CDI ADJUSTABLE HNBR PACKING ASSEMBLY

Ref No.	Name of Part	Qty.	Part No.
1	HEADER RING, 3"	1	595702000
2	PRESSURE RING	1	595694000
3	FEMALE ADAPTER	1	595686000
4	SPACER	1	595718000
5	WIPER SEAL	1	595710000
6	JUNK RING	1	302OPE317
7	PACKING NUT	1	302WPD008

CDI ADJUSTABLE HNBR PACKING

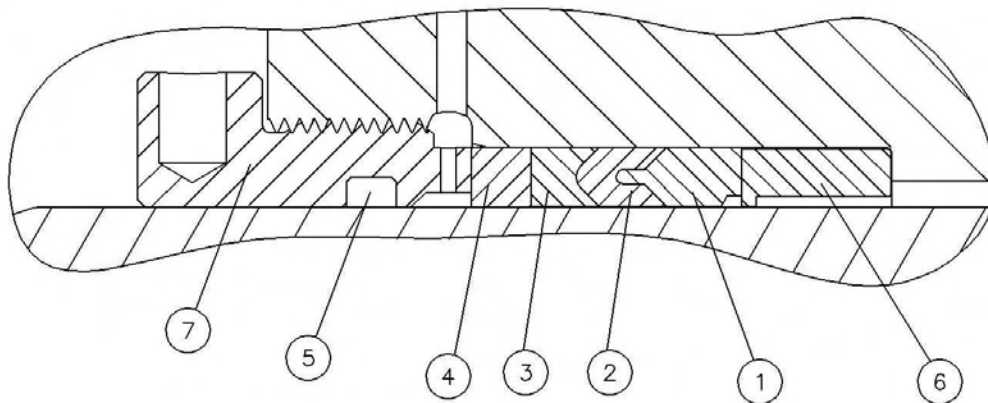

3.5" CDI ADJUSTABLE HNBR PACKING ASSEMBLY

Ref No.	Name of Part	Qty.	Part No.
1	HEADER RING, 3.5"	1	302OPE222
2	PRESSURE RING	1	309OPE222
3	FEMALE ADAPTER	1	308OPE170
4	SPACER	1	302OPE144
5	WIPER SEAL	1	60AM83
6	JUNK RING	1	303OPE317
7	PACKING NUT	1	303WPD008

4" CDI ADJUSTABLE HNBR PACKING ASSEMBLY

Ref No.	Name of Part	Qty.	Part No.
1	HEADER RING, 4"	1	303OPE222
2	PRESSURE RING	1	310OPE222
3	FEMALE ADAPTER	1	309OPE170
4	SPACER	1	303OPE144
5	WIPER SEAL	1	60AM84
6	JUNK RING	1	305OPE317
7	PACKING NUT	1	304WPD008

4.5" CDI ADJUSTABLE HNBR PACKING ASSEMBLY

Ref No.	Name of Part	Qty.	Part No.
1	HEADER RING, 4.5"	1	595704000
2	PRESSURE RING	1	595696000
3	FEMALE ADAPTER	1	595688000
4	SPACER	1	595720000
5	WIPER SEAL	1	60AM73
6	JUNK RING	1	306OPE317
7	PACKING NUT	1	305WPD008

CDI ADJUSTABLE HNBR PACKING

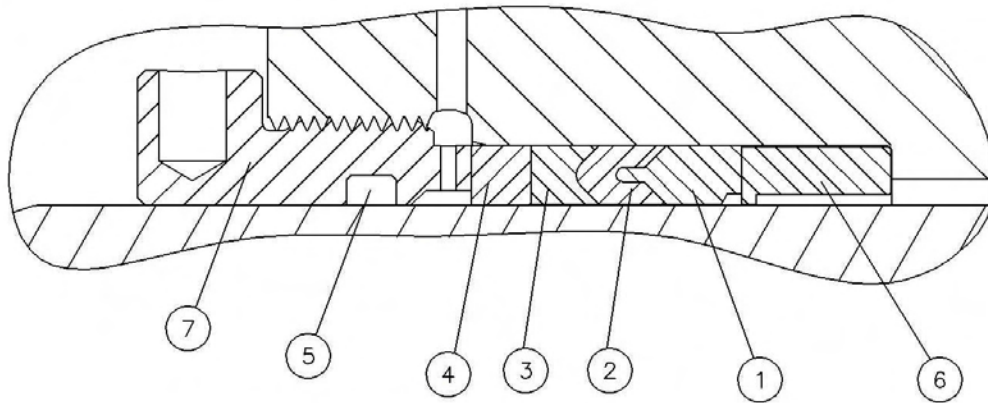

5" CDI ADJUSTABLE HNBR PACKING ASSEMBLY

Ref No.	Name of Part	Qty.	Part No.
1	HEADER RING, 5"	1	595705000
2	PRESSURE RING	1	595697000
3	FEMALE ADAPTER	1	595689000
4	SPACER	1	595721000
5	WIPER SEAL	1	60AM74
6	JUNK RING	1	307OPE317
7	PACKING NUT	1	306WPD008

CDI NON-ADJUSTABLE HNBR PACKING

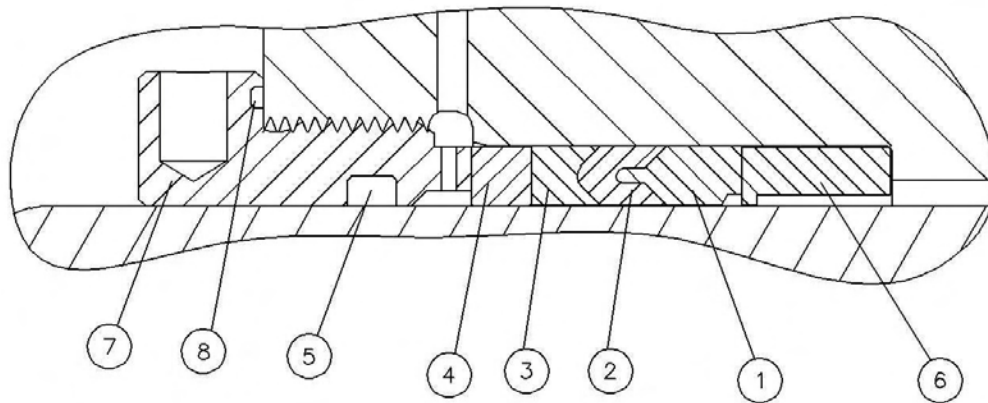

2.25" CDI NON-ADJUSTABLE HNBR PACKING ASSEMBLY

Ref No.	Name of Part	Qty.	Part No.
1	HEADER RING, 2.25"	1	300OPE222
2	PRESSURE RING	1	307OPE222
3	FEMALE ADAPTER	1	306OPE170
4	SPACER	1	300OPE144
5	WIPER SEAL	1	60AM81
6	JUNK RING	1	300WPD317
7	PACKING NUT	1	307WPD008
8	O-RING	1	137866

2.75" CDI NON-ADJUSTABLE HNBR PACKING ASSEMBLY

Ref No.	Name of Part	Qty.	Part No.
1	HEADER RING, 2.75"	1	301OPE222
2	PRESSURE RING	1	308OPE222
3	FEMALE ADAPTER	1	307OPE170
4	SPACER	1	301OPE144
5	WIPER SEAL	1	60AM82
6	JUNK RING	1	301WPD317
7	PACKING NUT	1	308WPD008
8	O-RING	1	137866

3" CDI NON-ADJUSTABLE HNBR PACKING ASSEMBLY

Ref No.	Name of Part	Qty.	Part No.
1	HEADER RING, 3"	1	595702000
2	PRESSURE RING	1	595694000
3	FEMALE ADAPTER	1	595686000
4	SPACER	1	595718000
5	WIPER SEAL	1	595710000
6	JUNK RING	1	302WPD317
7	PACKING NUT	1	309WPD008
8	O-RING	1	137866

CDI NON-ADJUSTABLE HNBR PACKING

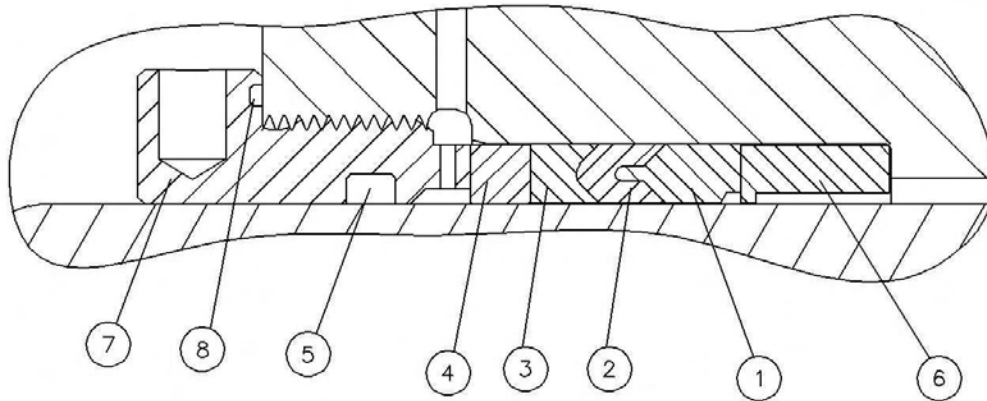

3.5" CDI NON-ADJUSTABLE HNBR PACKING ASSEMBLY

Ref No.	Name of Part	Qty.	Part No.
1	HEADER RING, 3.5"	1	302OPE222
2	PRESSURE RING	1	309OPE222
3	FEMALE ADAPTER	1	308OPE170
4	SPACER	1	302OPE144
5	WIPER SEAL	1	60AM83
6	JUNK RING	1	303WPD317
7	PACKING NUT	1	310WPD008
8	O-RING	1	901SH05-256

4" CDI NON-ADJUSTABLE HNBR PACKING ASSEMBLY

Ref No.	Name of Part	Qty.	Part No.
1	HEADER RING, 4"	1	303OPE222
2	PRESSURE RING	1	310OPE222
3	FEMALE ADAPTER	1	309OPE170
4	SPACER	1	303OPE144
5	WIPER SEAL	1	60AM84
6	JUNK RING	1	305WPD317
7	PACKING NUT	1	311WPD008
8	O-RING	1	901SH05-256

4.5" CDI NON-ADJUSTABLE HNBR PACKING ASSEMBLY

Ref No.	Name of Part	Qty.	Part No.
1	HEADER RING, 4.5"	1	595704000
2	PRESSURE RING	1	595696000
3	FEMALE ADAPTER	1	595688000
4	SPACER	1	595720000
5	WIPER SEAL	1	60AM73
6	JUNK RING	1	306WPD317
7	PACKING NUT	1	312WPD008
8	O-RING	1	167661

CDI NON-ADJUSTABLE HNBR PACKING

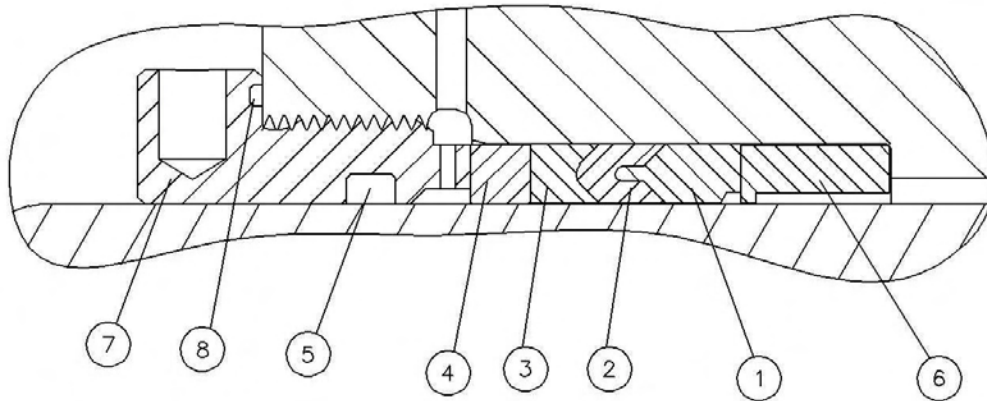

5" CDI NON-ADJUSTABLE HNBR PACKING ASSEMBLY

Ref No.	Name of Part	Qty.	Part No.
1	HEADER RING, 5"	1	595705000
2	PRESSURE RING	1	595697000
3	FEMALE ADAPTER	1	595689000
4	SPACER	1	595721000
5	WIPER SEAL	1	60AM74
6	JUNK RING	1	307WPD317
7	PACKING NUT	1	313WPD008
8	O-RING	1	167661

DISCHARGE OPTIONS FOR STANDARD FLUID ENDS

2" 1502 HAMMER UNION DISCHARGE FLANGE STANDARD FLUID ENDS

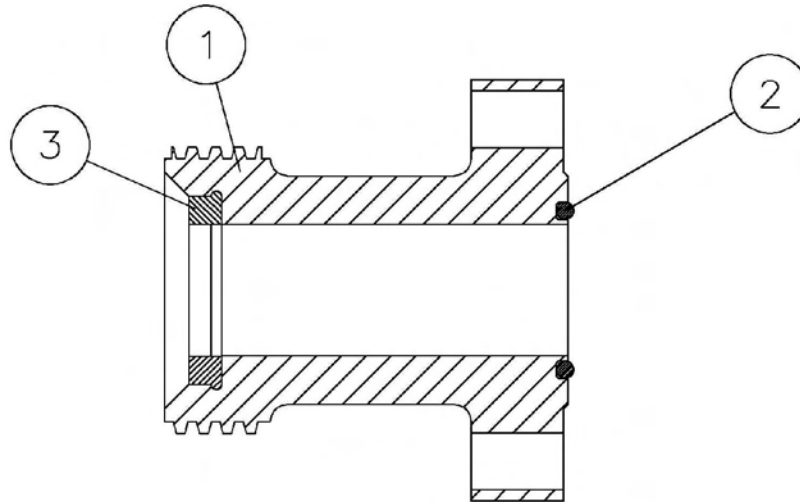

2-1/4" TO 3" FLUID ENDS

Ref No.	Name of Part	Qty.	Part No.
1	2" 1502 Female Flange – DNV Certified Material	1	267PN06
2	O-ring	1	107970
3	Seal – 2" 1502 Weco	1	901SH06-1

3-1/2" TO 4" FLUID ENDS

Ref No.	Name of Part	Qty.	Part No.
1	2" 1502 Female Flange – DNV Certified Material	1	267PN26
2	O-ring	1	107974
3	Seal – 2" 1502 Weco	1	901SH06-1

4-1/2" TO 5" FLUID ENDS

Ref No.	Name of Part	Qty.	Part No.
1	2" 1502 Female Flange – Standard Material	1	267PN07
	2" 1502 Female Flange – DNV Certified Material	1	PP1008293
2	O-ring	1	107977
3	Seal – 2" 1502 Weco	1	901SH06-1

**2.5" 1002 HAMMER UNION DISCHARGE FLANGE
STANDARD FLUID ENDS**

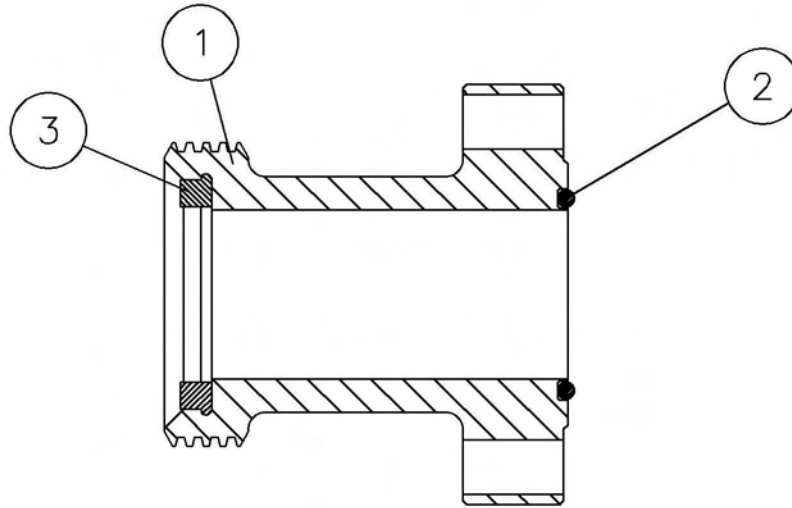

3-1/2" TO 4" FLUID ENDS

Ref No.	Name of Part	Qty.	Part No.
1	2.5" 1502 Female Flange – Standard Material	1	267PN08
	2.5" 1502 Female Flange – DNV Certified Material	1	PP1008294
2	O-ring	1	107974
3	Seal – 2.5" 1002 Weco	1	901SH06-3

**3" 1002 HAMMER UNION DISCHARGE FLANGE
STANDARD FLUID ENDS**

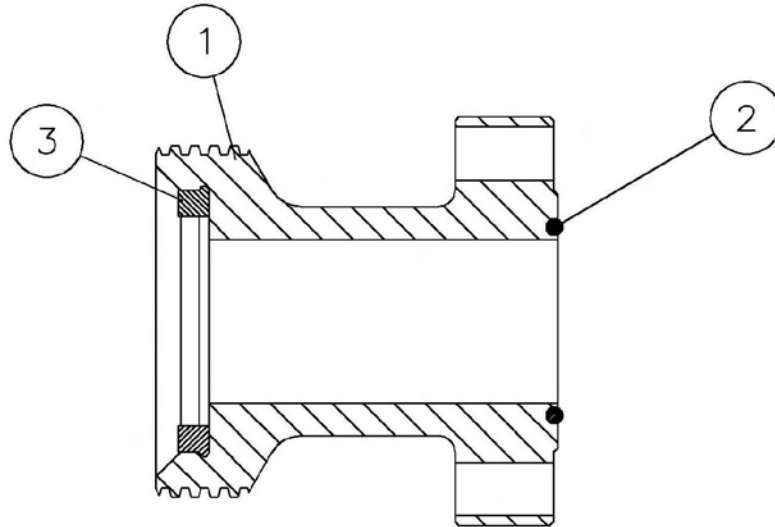

3-1/2" TO 4" FLUID ENDS

Ref No.	Name of Part	Qty.	Part No.
1	3" 1002 Female Flange – Standard Material	1	267PN13
	3" 1002 Female Flange – DNV Certified Material	1	PP1008295
2	O-ring	1	107974
3	Seal – 3" 1002 Weco	1	901SH06-2

4-1/2" TO 5" FLUID ENDS

Ref No.	Name of Part	Qty.	Part No.
1	3" 1002 Female Flange – Standard Material	1	267PN05
	3" 1002 Female Flange – DNV Certified Material	1	PP1008291
2	O-ring	1	107977
3	Seal – 3" 1002 Weco	1	901SH06-2

**3" 1502 FEMALE HAMMER UNION DISCHARGE FLANGE
STANDARD FLUID ENDS**

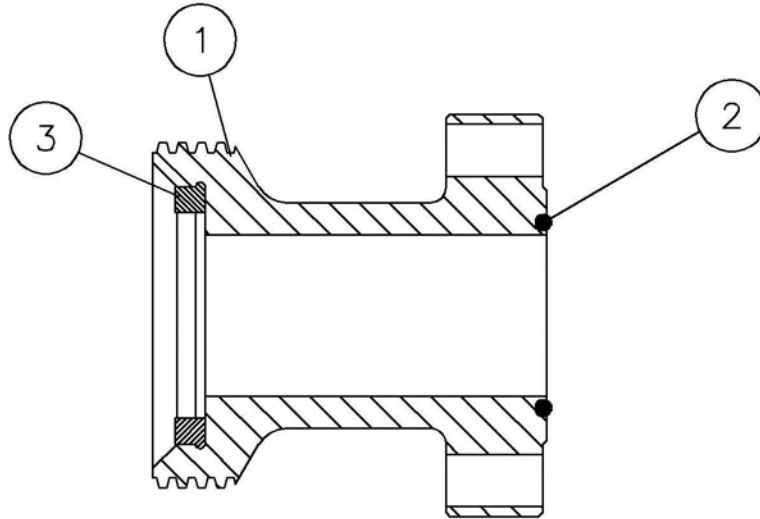

3-1/2" TO 4" FLUID ENDS

Ref No.	Name of Part	Qty.	Part No.
1	3" 1502 Female Flange – Standard Material	1	267PN029
	3" 1502 Female Flange – DNV Certified Material	1	PP1008297
2	O-ring	1	107974
3	Seal – 3" 1502 Weco	1	901SH06-2

4-1/2" TO 5" FLUID ENDS

Ref No.	Name of Part	Qty.	Part No.
1	3" 1502 Female Flange – Standard Material	1	267PN030
	3" 1502 Female Flange – DNV Certified Material	1	PP1008298
2	O-ring	1	107977
3	Seal – 3" 1502 Weco	1	901SH06-2

**BLEED OFF DISCHARGE FLANGE
STANDARD FLUID ENDS**

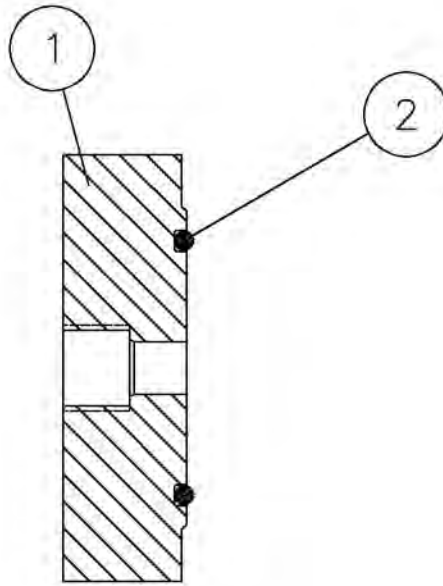

2-1/4" TO 3" FLUID ENDS

Ref No.	Name of Part	Qty.	Part No.
1	Bleed Off Flange – Standard Material	1	268PN04
	Bleed Off Flange – DNV Certified Material	1	PP1008300
2	O-ring	1	107970

3-1/2" TO 4" FLUID ENDS

Ref No.	Name of Part	Qty.	Part No.
1	Bleed Off Flange – Standard Material	1	268PN05
	Bleed Off Flange – DNV Certified Material	1	PP1008301
2	O-ring	1	107974

4-1/2" TO 5" FLUID ENDS

Ref No.	Name of Part	Qty.	Part No.
1	Bleed Off Flange – Standard Material	1	268PN01
	Bleed Off Flange – DNV Certified Material	1	PP1008299
2	O-ring	1	107977

**BLIND DISCHARGE FLANGE
STANDARD FLUID ENDS**

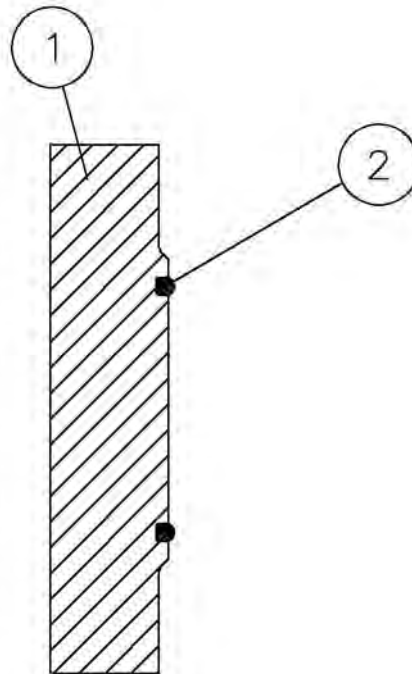

2-1/4" TO 3" FLUID ENDS

Ref No.	Name of Part	Qty.	Part No.
1	Blind Flange – Standard Material	1	265PN005
	Blind Flange – DNV Certified Material	1	PP1008289
2	O-ring	1	107970

3-1/2" TO 4" FLUID ENDS

Ref No.	Name of Part	Qty.	Part No.
1	Blind Flange – DNV Certified Material	1	265PN006
2	O-ring	1	107974

4-1/2" TO 5" FLUID ENDS

Ref No.	Name of Part	Qty.	Part No.
1	Blind Flange – Standard Material	1	265PN004
	Blind Flange – DNV Certified Material	1	PP1008288
2	O-ring	1	107977

DISCHARGE OPTIONS FOR AUTOFRETTAGED FLUID ENDS

DISCHARGE PORT BUSHING & O-RINGS ASSEMBLY AUTOFRETTAGED FLUID ENDS

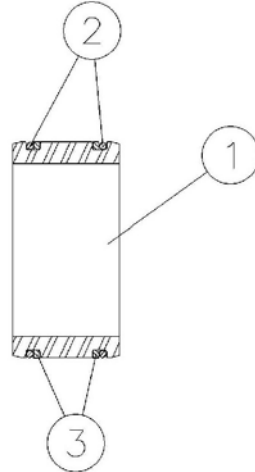

Assembly Part Number: 405TWC4038

Ref No.	Name of Part	Qty.	Part No.
1	Port Bushing	1	403400090
2	O-ring	2	169828
3	Back-up Ring (for Item 2)	2	429003000

BLIND DISCHARGE FLANGE ASSEMBLY AUTOFRETTAGED FLUID ENDS

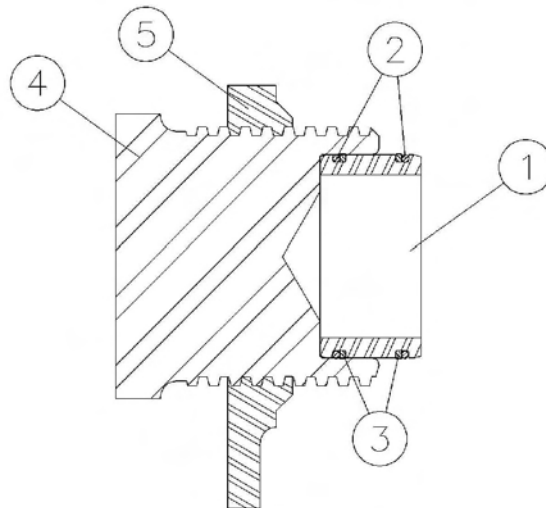

Assembly Part Number: 400TWC4038

Ref No.	Name of Part	Qty.	Part No.
1	Port Bushing	1	403400090
2	O-ring	2	169828
3	Back-up Ring (for Item 2)	2	429003000
4	Plug	1	403404090
5	Wing Nut	1	403403000

**2" 1502 FEMALE DISCHARGE FLANGE ASSEMBLY
AUTOFRETTAGED FLUID ENDS**

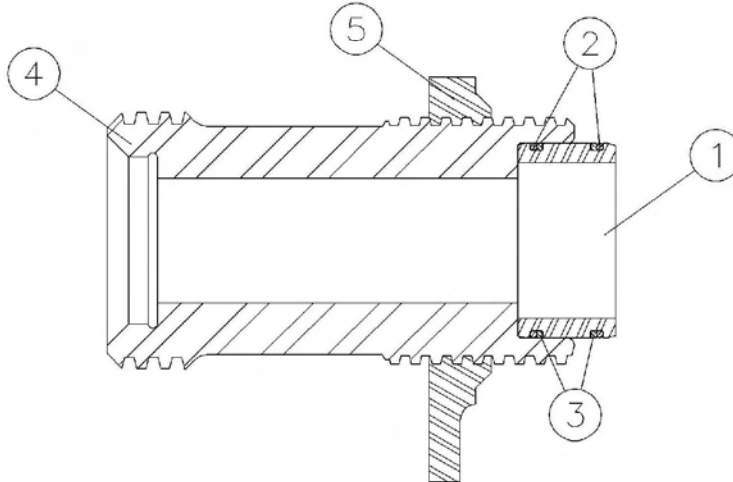

Assembly Part Number: 402TWC4038

Ref No.	Name of Part	Qty.	Part No.
1	Port Bushing	1	403400090
2	O-ring	2	169828
3	Back-up Ring (for Item 2)	2	429003000
4	2" 1502 Female Treating Adapter	1	479197090
5	Wing Nut	1	403403000

**3" 1502 FEMALE DISCHARGE FLANGE ASSEMBLY
AUTOFRETTAGED FLUID ENDS**

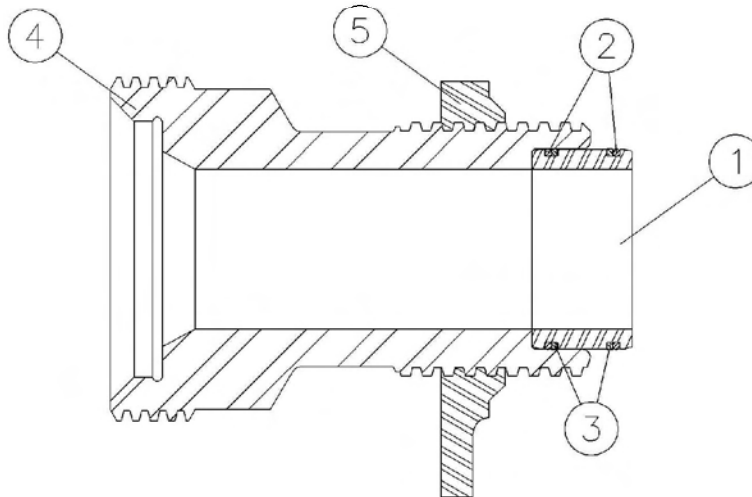

Assembly Part Number: 403TWC4038

Ref No.	Name of Part	Qty.	Part No.
1	Port Bushing	1	403400090
2	O-ring	2	169828
3	Back-up Ring (for Item 2)	2	429003000
4	3" 1502 Female Treating Adapter	1	520915090
5	Wing Nut	1	403403000

**2" 2002 FEMALE DISCHARGE FLANGE ASSEMBLY
AUTOFRETTAGED FLUID ENDS**

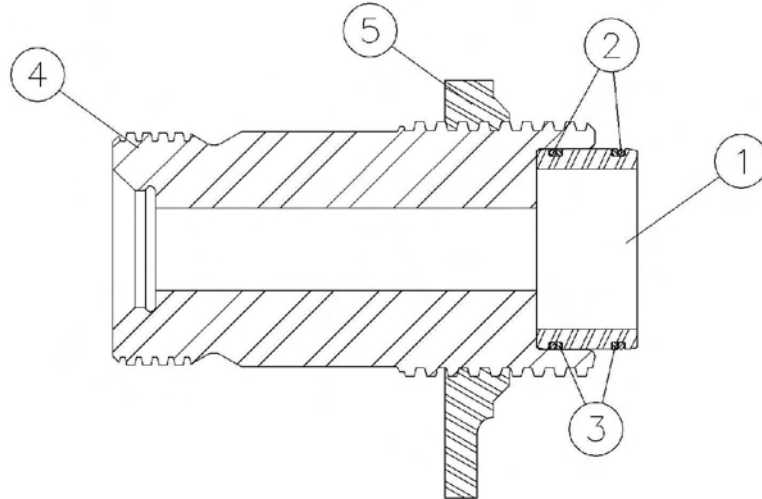

Assembly Part Number: 404TWC4038

Ref No.	Name of Part	Qty.	Part No.
1	Port Bushing	1	403400090
2	O-ring	2	169828
3	Back-up Ring (for Item 2)	2	429003000
4	2" 2002 Female Treating Adapter	1	PP1001852
5	Wing Nut	1	403403000

SUCTION MANIFOLD OPTIONS

4" SUCTION MANIFOLD WITH VICTAULIC ENDS

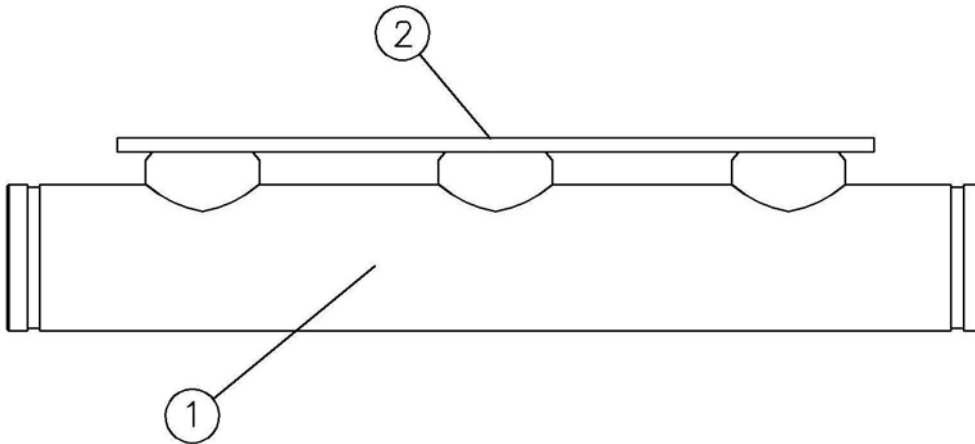

2-1/4" TO 3" FLUID ENDS

Ref No.	Name of Part	Qty.	Part No.
1	Suction Manifold	1	304WPD069
2	O-ring	3	107981

3-1/2" TO 5" FLUID ENDS

Ref No.	Name of Part	Qty.	Part No.
1	Suction Manifold	1	117PN010
2	O-ring	3	25BC333

4" SUCTION MANIFOLD WITH VICTAULIC ENDS AND VALVE LIFTERS

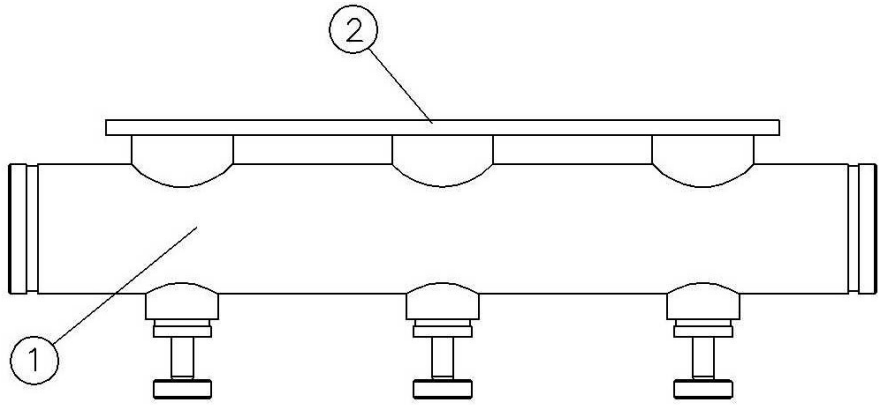
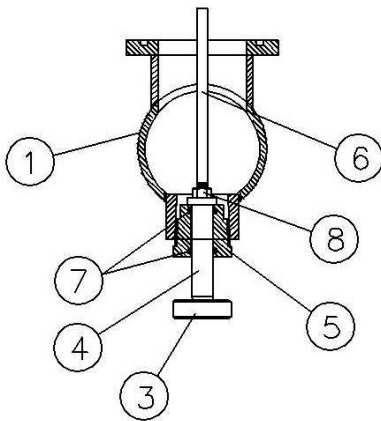

2-1/4" TO 3" FLUID ENDS

Ref No.	Name of Part	Qty.	Part No.
1	Suction Manifold	1	116PN006
2	O-ring	3	107981
3	Lifter Disc	3	595PN01
4	Lifter Shaft	3	595PN02
5	Coupling	3	595PN03
6	Push Rod	3	595PN04
7	O-ring	6	107956
8	Hex Nut	3	50AQ3

3-1/2" TO 5" FLUID ENDS

Ref No.	Name of Part	Qty.	Part No.
1	Suction Manifold	1	116PN005
2	O-ring	3	25BC333
3	Lifter Disc	3	595PN01
4	Lifter Shaft	3	595PN02
5	Coupling	3	595PN03
6	Push Rod	3	595PN04
7	O-ring	6	107956
8	Hex Nut	3	50AQ3

6" SUCTION MANIFOLD WITH VICTAULIC ENDS

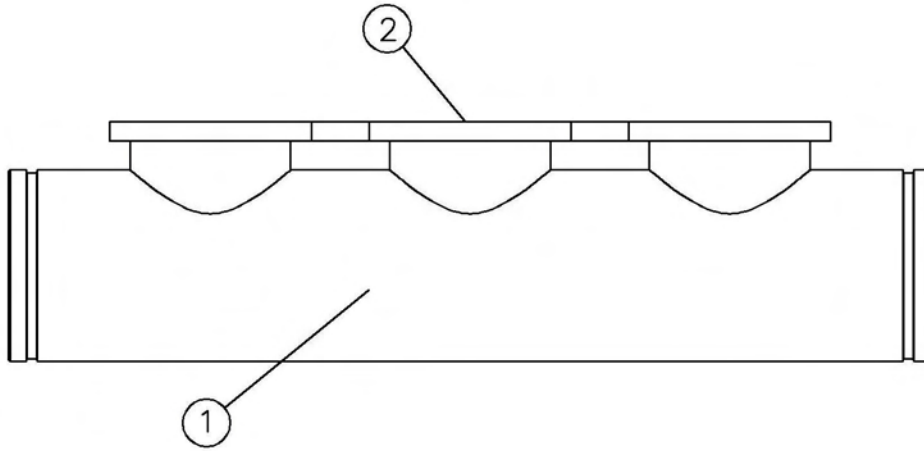

2-1/4" TO 3" FLUID ENDS

Ref No.	Name of Part	Qty.	Part No.
1	Suction Manifold	1	117PN005
2	O-ring	3	107981

3-1/2" TO 5" FLUID ENDS

Ref No.	Name of Part	Qty.	Part No.
1	Suction Manifold	1	117PN006
2	O-ring	3	25BC333

6" SUCTION MANIFOLD WITH VICTAULIC ENDS AND VALVE LIFTERS

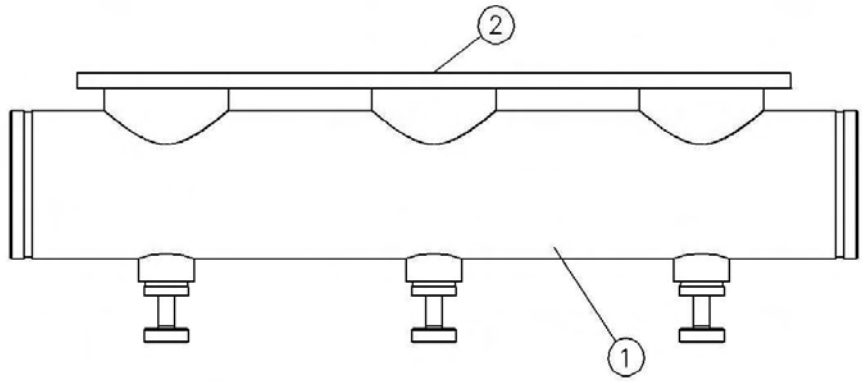
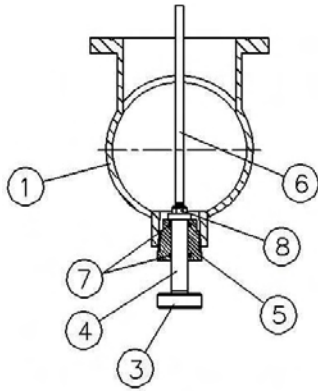

2-1/4" TO 3" FLUID ENDS

Ref No.	Name of Part	Qty.	Part No.
1	Suction Manifold	1	116PN004
2	O-ring	3	107981
3	Lifter Disc	3	595PN01
4	Lifter Shaft	3	595PN02
5	Coupling	3	595PN03
6	Push Rod	3	595PN04
7	O-ring	6	107956
8	Hex Nut	3	50AQ3

3-1/2" TO 5" FLUID ENDS

Ref No.	Name of Part	Qty.	Part No.
1	Suction Manifold	1	116PN002
2	O-ring	3	25BC333
3	Lifter Disc	3	595PN01
4	Lifter Shaft	3	595PN02
5	Coupling	3	595PN03
6	Push Rod	3	595PN04
7	O-ring	6	107956
8	Hex Nut	3	50AQ3

4" SUCTION MANIFOLD WITH VICTAULIC ENDS & CLEANOUTS

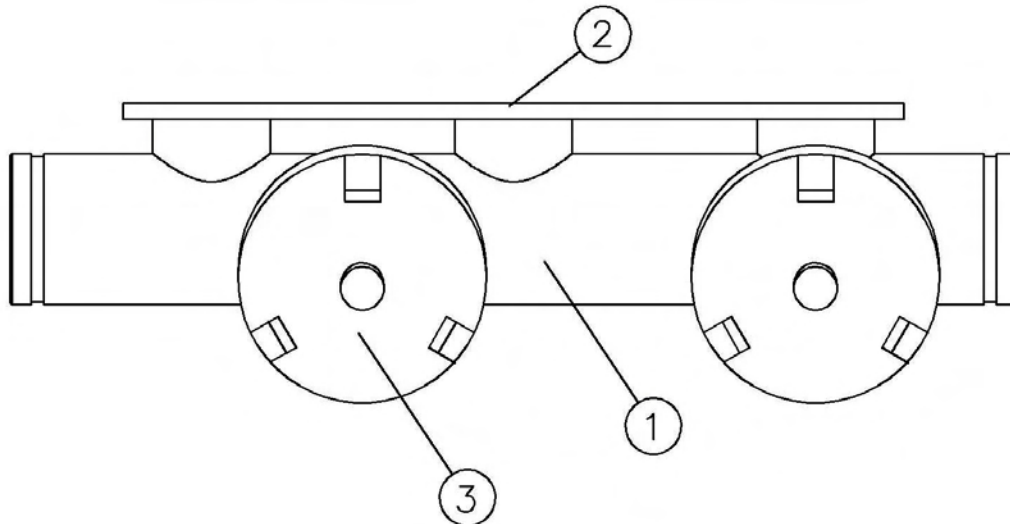

2-1/4" TO 3" FLUID ENDS

Ref No.	Name of Part	Qty.	Part No.
1	Suction Manifold	1	305WPD069
2	O-ring – Fluid End	3	107981
3	Cap – Cleanout with O-ring	2	415413000

5" SUCTION MANIFOLD WITH VICTAULIC ENDS

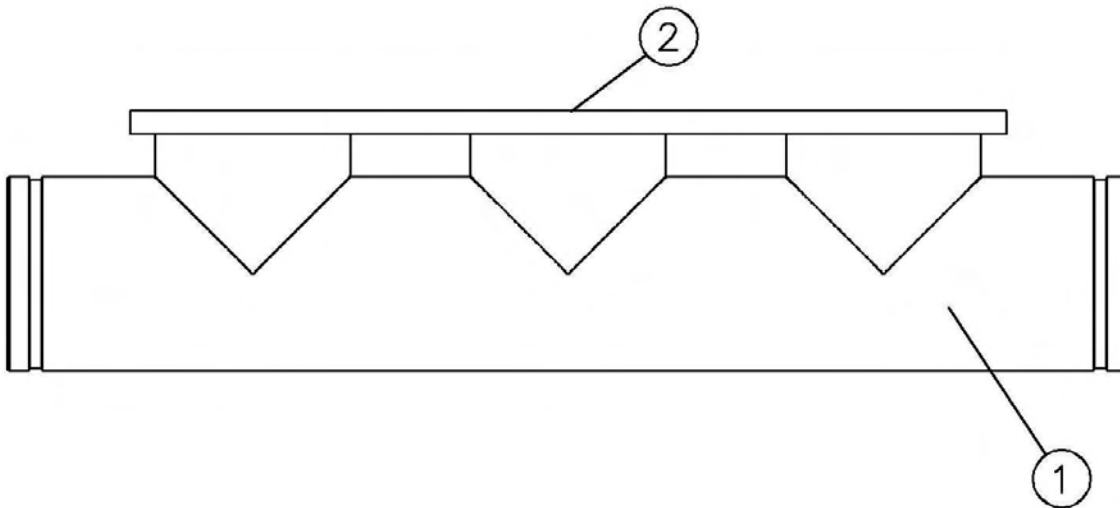

3-1/2" TO 5" FLUID ENDS

Ref No.	Name of Part	Qty.	Part No.
1	Suction Manifold	1	PP1003452
2	O-ring – Fluid End	3	25BC333

5" SUCTION MANIFOLD WITH 150# RF FLANGE ENDS

With Extended Drop

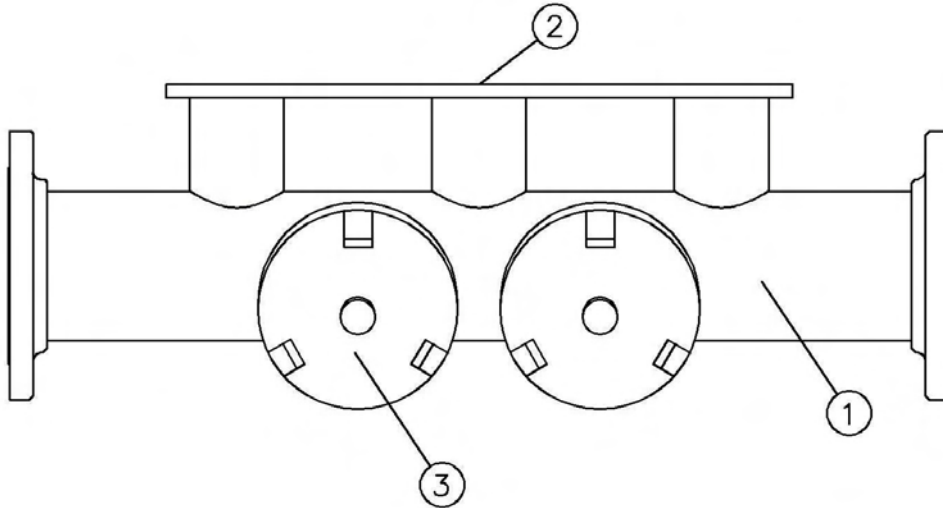

2-1/4" TO 3" FLUID ENDS

Ref No.	Name of Part	Qty.	Part No.
1	Suction Manifold	1	PP1003864
2	O-ring	3	107981
3	Cap – Cleanout with O-ring	2	415413000

5" SUCTION MANIFOLD WITH 150# RF FLANGE ENDS

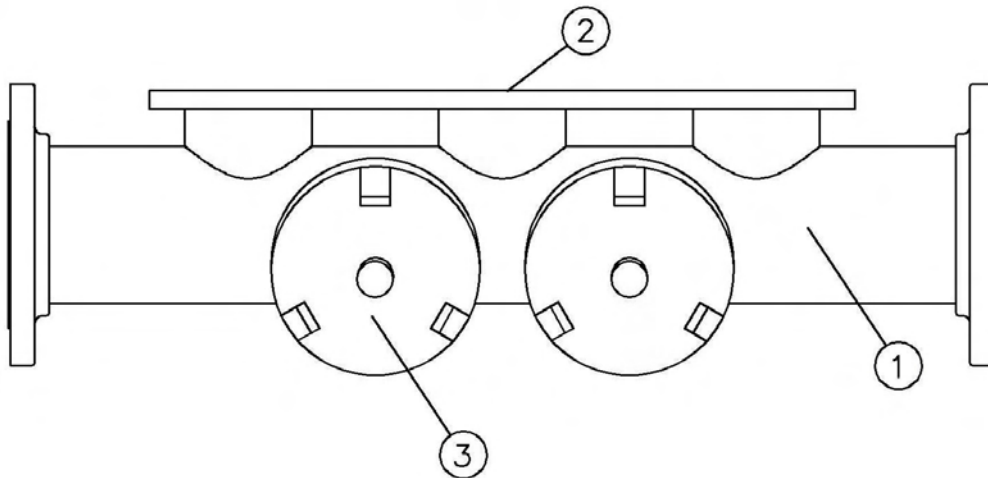

3-1/2" TO 5" FLUID ENDS

Ref No.	Name of Part	Qty.	Part No.
1	Suction Manifold	1	PP1003865
2	O-ring	3	25BC333
3	Cap – Cleanout with O-ring	2	415413000

FLUID END SERVICE TOOLS

2-1/4" FLUID END

Ref No.	Name of Part	Qty.	Part No.
1	Packing Nut Wrench	1	200OPB933
2	2" Hex Wrench	1	P-A-09
3	Slide Hammer Puller	1	590PN006

2-3/4" THRU 4" STANDARD FLUID ENDS

Ref No.	Name of Part	Qty.	Part No.
1	Packing Nut Wrench	1	200OPB933
2	2" Hex Wrench	1	P-A-09
3	Slide Hammer Puller	1	590PN006
4	Valve Spring Compressor	1	211AD01-3
5	Puller - Suction Valve Spring Retainer	1	590PN01

2-3/4" THRU 3" AUTOFRETTAGED FLUID ENDS

Ref No.	Name of Part	Qty.	Part No.
1	Packing Nut Wrench	1	200OPB933
2	2" Hex Wrench	1	P-A-09
3	Slide Hammer Puller	1	590PN006
4	Slide Hammer Left-hand Thread Adapter	1	PP1001580
5	Jam Nut	1	50B5
6	Valve Spring Compressor	1	211AD01-3
7	Puller - Suction Valve Spring Retainer	1	590PN01

4-1/2" THRU 5" FLUID ENDS

Ref No.	Name of Part	Qty.	Part No.
1	Packing Nut Wrench	1	200OPB933
2	2" Hex Wrench	1	P-A-09
3	Slide Hammer Puller	1	590PN006
4	Valve Spring Compressor	1	211AD01-4
5	Puller - Suction Valve Spring Retainer	1	590PN01

VALVE SEAT PULLER KITS

Ref No.	Name of Part	Qty.	Part No.
1	2.25" Valve Seat Puller Kit* (*Includes the following 3 items)	1	403WPD2041
	* Seat Puller Rod/Wedge Assembly	1	QBX91108
	* Puller Head Assembly	1	203QBX219
2	2.75" – 3" Valve Seat Puller Kit* (*Includes the following 3 items)	1	406THD6031
	* Seat Puller Jack Assembly	1	PP1013245
	* Puller Head Assembly	1	HY-1
	* Tool Box	1	H-400
3	3.5" – 4" Valve Seat Puller Kit* (*Includes the following 3 items)	1	402THD6031
	* Seat Puller Jack Assembly	1	102014
	* Puller Head Assembly	1	HG-3
	* Tool Box	1	H-400
4	4.5" – 5" Valve Seat Puller Kit* (*Includes the following 3 items)	1	403THD6031
	* Seat Puller Jack Assembly	1	102014
	* Puller Head Assembly	1	HR-4
	* Tool Box	1	H-400



For additional information contact your local representative or

Gardner Denver Inc.
4747 South 83rd East Avenue, Tulsa, OK 74145
PH: (918) 664-1151, (800) 637-8099
FAX: (918) 664-6225
www.gardnerdenver.com

Specifications subject to change without notice.
Copyright © 2005 Gardner Denver, Inc. Litho in U.S.A.